

XEROX
820/820-II PROCESSOR
SERVICE MANUAL
600P84592
MAY, 1982

Prepared by:
Xerox Corporation
Office Products Division
Customer Service
Field Engineering
1341 W. Mockingbird Lane
Dallas, Texas 75247

Copyright©1982 by Xerox Corporation
Xerox® is a registered trademark of Xerox Corporation
Printed in USA

TABLE OF CONTENTS

<p>1.0 GENERAL DATA</p> <p>1.1 How to Use this Manual 1-1</p> <p>1.2 Specifications 1-1</p> <p>1.3 Call Management 1-2</p> <p>1.3.1 General 1-2</p> <p>1.3.2 Call Management Procedure 1-3</p> <p>1.4 Supplemental Tools and Supplies 1-3</p> <p>1.5 Change Tag Index 1-3</p> <p>1.6 Applicable Documents 1-5</p> <p>2.0 INSTALLATION</p> <p>2.1 Preinstall Checkout 2-1</p> <p>2.2 Unpack Machine 2-1</p> <p>2.3 Set Up. 2-1</p> <p>2.4 Installation Check List. 2-3</p> <p>3.0 REPAIR DATA</p> <p>3.1 DISPLAY/PROCESSOR</p> <p>3.1.1 Display/Processor Covers 3-1</p> <p>3.1.2 CRT/ PWA 3-1</p> <p>3.1.3 Power Supply 3-3</p> <p>3.1.4 Main/Processor PWA 3-3</p> <p>3.1.5 Power On/Off Switch 3-5</p> <p>3.1.6 Brightness Control 3-5</p> <p>3.2 KEYBOARD ASSEMBLY</p> <p>3.2.1 Keyboard Covers 3-5</p> <p>3.2.2 Keyboard PWA 3-6</p> <p>3.2.3 Keyboard Harness Assembly 3-6</p> <p>3.3 DISK DRIVE ASSEMBLY (5.25")</p> <p>3.3.1 Disk Covers 3-7</p> <p>3.3.2 Disk Drive 3-7</p> <p>3.3.3 Head Load Pad 3-8</p> <p>3.3.4 Disk Drive Belt 3-8</p> <p>3.3.5 Disk Drive Harness 3-9</p> <p>3.4 DISK DRIVE ASSEMBLY (8")</p> <p>3.4.1 Disk Drive Covers. 3-9</p> <p>3.4.2 Disk Drive(s) 3-10</p> <p>3.4.3 Load Pad, Single Side Disk Drive 3-12</p> <p>3.4.4 8" Disk Drive Power Supply. 3-13</p> <p>3.5 FIXED DRIVE ASSEMBLY (8" FIXED)</p> <p>3.5.1 Disk Covers 3-13</p> <p>3.5.2 Disk Fixed Controller PWA. 3-14</p> <p>3.5.3 Fixed Drive 3-14</p> <p>3.5.4 10 MB Control PWA 3-14</p> <p>3.5.5 10 MB Stepper PWA 3-15</p> <p>3.5.6 10 MB Disk Motor/Belt 3-15</p> <p>3.5.7 Damper Assembly. 3-16</p> <p>3.5.8 Fixed Disk Assembly Adjustments 3-17</p> <p>3.5.9 Interlock Switch 3-19</p>	<p>4.0 PARTS IDENTIFICATION</p> <p>PL 4.1 Display/Processor</p> <p>PL 4.2 Keyboard Assembly</p> <p>PL 4.3 Disk Drive Assembly (5.25" SS/DS).</p> <p>PL 4.4 Disk Drive Assembly (8" SS/DS).</p> <p>PL 4.5 Disk Drive Assembly (8" Fixed)</p> <p>PL 4.5 8" Fixed Drive</p> <p>5.0 DISPLAY QUALITY</p> <p style="text-align: center;">N/A</p> <p>6.0 TROUBLESHOOTING</p> <p>6.1 Introduction</p> <p>6.2 Level 1 Checkout Explanation</p> <p>6.3 Level 2 Checkout Explanation</p> <p>6.4 Level 1 Checkout Procedures</p> <p>6.5 Level 2 Check Chart Procedures</p> <p>6.6 Chain 1.1 AC/DC Power Distribution</p> <p>7.0 PLUG/JACK LIST</p> <p>7.1 Plug/Jack Location</p> <p>7.2 Plug/Jack Terminal Identification</p> <p>7.3 Wire Run Lists</p> <p>8.0 THEORY OF OPERATIONS</p> <p style="text-align: center;">System Block Diagrams</p> <p style="text-align: center;">820/820-II</p> <p style="text-align: center;">Power Block Diagram</p> <p style="text-align: center;">SA1403D Interconnect.</p> <p>8.1 General</p> <p>8.2 DC Power Supply</p> <p>8.3 Processor (CPU) PWA</p> <p>8.4 Daughter PWA</p> <p>8.4 Disk Drive Assembly (5.25" SS)</p> <p>8.5 Disk Drive Assembly (8" SS)...</p> <p>8.6 5.25" and 8" Dual Sided</p> <p>8.7 CRT Assembly</p> <p>8.8 Keyboard Assembly</p> <p>8.9 1403D Disc Controller</p> <p>8.10 SA1004 Fixed Drive</p> <p>8.11 CP/M Introduction</p> <p>9.0 SCHEMATIC DIAGRAMS</p>
------------------------------------------------------------------------------------------------------------------------------------------------------------------------------------------------------------------------------------------------------------------------------------------------------------------------------------------------------------------------------------------------------------------------------------------------------------------------------------------------------------------------------------------------------------------------------------------------------------------------------------------------------------------------------------------------------------------------------------------------------------------------------------------------------------------------------------------------------------------------------------------------------------------------------------------------------------------------------------------------------------------------------------------------------------------------------------------------------------------------------------------------------------------------------------------------------------------------------------------------------------------------------------------------------------------------------------------------------------------------------------------------------------------------------------------------------------------------------------------------------------------------------------------------------------------------------------------------------------------------------------------------------------------------------------------------------------------------------------------------------------------------------------------------------------------------------------------------------------------------------------------------------------------------------------------------------------------------------------------------------------------------------------------------------------------------------------------------------------------------------------------------	---------------------------------------------------------------------------------------------------------------------------------------------------------------------------------------------------------------------------------------------------------------------------------------------------------------------------------------------------------------------------------------------------------------------------------------------------------------------------------------------------------------------------------------------------------------------------------------------------------------------------------------------------------------------------------------------------------------------------------------------------------------------------------------------------------------------------------------------------------------------------------------------------------------------------------------------------------------------------------------------------------------------------------------------------------------------------------------------------------------------------------------------------------------------------------------------------------------------------------------------------------------------------------------------------------------------------------------------------------------------------------------------------------------------------------------------------------------------------------------------------------------------------------------------------------------------------------------------------------------------------------------------------------------------------------------------------------------------------------

GENERAL DATA

1.1 HOW TO USE THIS MANUAL

The XEROX 820/820-II IP Processor MANUAL contains the necessary information for service and maintenance.

The Service Manual is divided into the following Chapters:

Chapter 1. GENERAL DATA

Contains information on the use of the service manual, general specifications, change tag information, and supplemental tools and supplies list.

Chapter 2. INSTALLATION

Contains information required for machine installation.

Chapter 3. REPAIR

Contains removal, replacement, and adjustment procedures which are indexed by number to the related parts list in Chapter 4 (Parts Identification).

Chapter 4. PARTS IDENTIFICATION:

Provides exploded views of all spared parts (and their configuration) which are indexed to the item number and description of the spared parts list. The following codes are provided in Parts Identification to show that a Removal/Replacement, Adjustment, or a Removal/Replacement and Adjustment procedure is provided in the Repair information.

- | | |
|----------|--------------------------------|
| 6 | Remove/Replace |
| 7 | Adjustment |
| 8 | Remove/Replace and Adjustment. |

The number in the box is the number of the repair procedure.

Chapter 5. DISPLAY QUALITY

NA

Chapter 6. TROUBLESHOOTING

Provides the troubleshooting approach which begins by viewing all visual indicators in their normal sequence of operation. The first incorrect visual indicator will provide access to a fault isolation/repair procedure.

MANUAL REVISION MARKS

Revision pages for the Service Manual tell of configuration modifications. When a page is changed or added, a revision letter on the bottom of the page will identify it as a revised page. The actual change will be identified as follows:

- | | | |
|--------|--|------------------------------------------|
| Text | | Black vertical bar in the left, margin. |
| Tables | | Black vertical bar left of changed data. |





- | | | |
|----------------------|--|-------------------------------------|
| Changed Illustration | | Black vertical bar to area changed. |
| New Illustrations | | Black vertical bar to art number. |

If the same page is changed by a later revision, the identification marks will be removed and identification marks added to the new information.

A new title page with a revision Control List will be with each Change Package. This list will contain the number of each changed or added page as well as a revision letter of that page. Pages not listed are old or previous revision pages.

BASIC SIGNS USED IN THIS MANUAL

Four signs are used to show areas or sections in Service Manual which have been affected by a tag change.

- | | |
|---------------------------------------------------------------------------------------|-------------------------------------------------------------------------------------------------------------------------------|
|  | This sign is used to show a particular part area of a figure which has been modified by the tag number within the circle. |
|  | This sign is used to show a particular part area of a figure which has not been modified by the tag number within the circle. |
|  | This sign is used to show a tag change has modified an area of the machine. |
|  | This sign is used to show a tag change has modified an area of the machine. |

COMMENT SHEET USAGE

You can help improve the Service Manual by identifying errors, providing input for improvements, and stating reasons. A publication comment sheet is located rear of this manual. It contains instructions for completion. An answer will be sent to you upon request.

1.2 SPECIFICATIONS

Product Codes	U 5
820 Processor	927
820-II Processor (Floppy)	U03
820-II Processor (Fixed)	U05
Keyboard Unit	928
Disc Drive Assembly (5.25" 5S)	929
Disc Drive Assembly (8" 5S)	973
Disc Drive Assembly (Fixed)	U07
Disc Drive Assembly (5.25" DS)	T66
Disc Drive Assembly (8" DS)	F10
Dimensions	

Display/Controller

Width	(15.0")	(38.1cm)
Depth	(13.5")	(34.3cm)
Height	(13")	(33.0cm)
Weight	(30 lbs)	(13.6Kg)

Keyboard Unit

Width	(20.0")	(50.8cm)
Depth	(9.5")	(24.1cm)
Height	(3.75")	(9.5cm)
Weight	(10 lbs)	(4.5Kg)

1. GENERAL DATA

1.2 Specifications 1.3 Call Management

600P845

1.2 SPECIFICATIONS

Disk Assembly 5.25"

Width	8.0"	(20.3cm)
Depth	9.0"	(22.8cm)
Height	6.7"	(17.0cm)
Weight	10 lbs	(4.5Kg)

Disk Assembly 8"

Width	13.0"	(33.0cm)
Depth	22.75"	(57.8cm)
Height	11.25"	(28.6cm)
Weight	48 lbs	(21.8Kg)

Fixed Drive Assembly (8")

Width	15.5"	(39.4 cm)
Depth	22.75"	(57.8 cm)
Height	11.25"	(28.6 cm)
Weight	54lbs.	(24.5 kg)

Space Requirements

The minimum space requirements around the machine as shown (Figure 1-1) are needed for both normal operator functions and service maintenance functions.

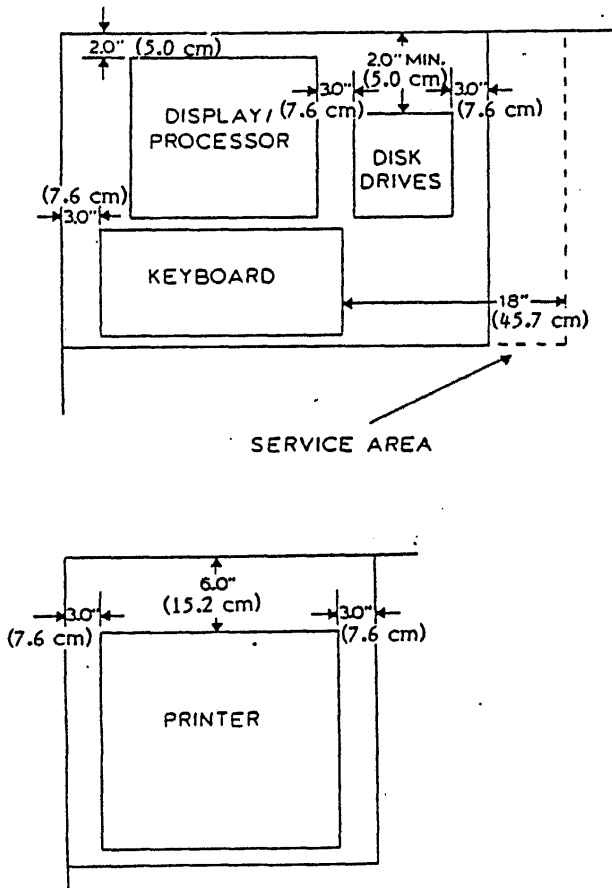

Figure 1-1 Space Requirements

Electrical Voltage

	U.S.	R.X.
Normal	115VAC	220V-240V
Minimum	90VAC	193V-215V
Maximum	132VAC	242V-264V
	60HZ±0.5HZ	50HZ ± 0.5HZ

A standard two pole, three wire grounded receptacle required.

Environmental

Temperature	50° to 90°F (10° to 32°C)
Humidity	15% to 85% at 78°F (25°C) (NON CONDENSING)
Elevation	6,000 feet above sea level. (1800 Meter)

1.3 CALL MANAGEMENT

1.3.1 General

The Call Management procedure is to be performed on every service call. Call Management will ensure that all critical areas of the 820 are in specification and operational. Performance of Call Management will enable a high level of service targets to be met, assuming a proper territory alignment.

The materials listed in Table 1-1 are required to perform the Call Management procedure.

Table 1-1 Call Management

Materials	Part No.	(USO)	(RX)
Head Load Pad 5.25"	6015868		76S2
Head Load Pad 8"	6015547		3P8
Anti-Static Cleaner	6015747		600T9
Film Remover	8R90020		8R9
Drum Polishing Paper	43P46		4
Clean-Ups (Box of 50)	43P67		4
Cleaning Solvent	43P78		600T9
Oil Lo-17	70H23		600T9
Paper Towel Packet			8K9
Lint Free Cloth	35P2163		35F
Wax Wiping Cloth	35P1638		35F
Cleaning Kit (51/4)	73P80439		73P8
Cleaning Kit (8")	73P80400		73P8C
Cleaning Solution	43P80006		43P8

The Call Management steps are presented in a sequence that will avoid backtracking and repeat operations.

Remember, when performing a Call Management, do it in the customer's office. Try not to interrupt the office operation. Keep your work area clean and as organized as possible; do not scatter tools and parts around. Use a bucket of solvent-soaked towels in proper receptacle.

1. GENERAL DATA

1.5 Change Tag Index

600P84

The information in this manual is applicable to all machines which have not been modified beyond the standard indicated by the modification plates. Refer to the appropriate modification leaflets for additional information when a machine has been modified to a later standard.

RX machines use a 10 digit serial number system in which the digits underscored designate the sequential change in number.

111 - XXXXXXX 820 Display Processor
(E 39)

NOTE: All machines manufactured after January 1, 1982 will have 131-XXXXXXXX.

1.5.3 Matrix Tag

The matrix tag for the 820/820-II Processor is located on the top of the CRT support. Any retrofit made to the machine must be marked on the matrix tag. The matrix tag for the disk drive assembly and the keyboard assembly are located on the bottom cover of that particular assembly.

CHANGE TAG INDEX

PROCESSOR

<u>TAG #</u>	<u>DISCRIPTION</u>	<u>CUT IN</u>
1	2.0 Rom Level CPU PWA	
2	Etch 2 Level CPU PWA (RXO)	131-303-

8" DISK DRIVE BOX

<u>TAG #</u>	<u>DISCRIPTION</u>
1	Universal AC Harness (RXO)

1.3.2 CALL MANAGEMENT PROCEDURE

Items marked with an asterisk (*) are to be performed only once within a 6-month period.

Paragraph references in the following steps are to procedures in Chapter 3.

A Call Management checklist follows the Call Management procedure.

XEROX 820/820-II Processor

1. Check connector panel and ensure connectors are properly secured.
2. Check display (CRT) alignment (3.1.2).
3. Turn system power OFF.
4. Remove top cover (3.1.1).
5. Clean face of CRT with general purpose cleaner and antistatic cleaner (6015747).
- *6. Clean back of CRT with wax wiping cloth.

NOTE: Do not remove PWA unless necessary.

7. Brush/clean PWA.
8. Ensure connectors are properly seated.
9. Replace head load pads if necessary (3.3.3/3.4.3).
10. Install top cover (3.1.1).
11. Turn system power ON.
12. Perform disc head cleaning procedure provided on the head cleaning kit package.
13. Run Diagnostics
14. Operate system to ensure proper operation.
15. Perform printer (terminal) periodic maintenance (1700 series Communications Terminal Service Manual).
16. Complete machine records.

CALL MANAGEMENT CHECKLIST

1. Ensure connectors on connector panel are secure.
2. Check display (CRT) alignment.
3. Remove top cover.
4. Clean face of CRT.
5. Clean back of CRT.
6. Clean PWA.
7. Check connectors.
8. Check load pads.
9. Install top cover.
10. Operate system.
11. Perform printer maintenance.
12. Complete machine records.

1.4 SUPPLEMENTAL TOOLS AND SUPPLIES

Supplemental tools are in addition to the 850/860 I Hire Tool Kit (600T1391) and the 1700 Terminal Set Supplemental Tools. The tools listed in Table 1-1 are required to service the XEROX 820/820-II Set Processor.

Table 1-1 Supplemental Tools

600T1504	Loop Back Tool
73SXXXX	Diagnostic Disc
600P83475	P-1/1730/630 Service M

Table 1-2 is a list of miscellaneous supplies.

Table 1-2 Consumables

12P422	TY Wrap
99P3049	Fuse, 2.5A (USO)
708W1601	Fuse, 2.0 AMP (RX)
708W9501	Fuse, 1.25A (RXC)
708W5001	Fuse, 4.0 AMP (R)

1.5 CHANGE TAG INDEX

1.5.1 Introduction (USO)

All significant changes to the machine, which installed in the factory or in the field, are identified by a tag number and a priority letter. They are listed in the Change Tag Index. The priority of change is designated as follows:

- M - mandatory
- O - optional
- N - not for field retrofit

Also shown is the description of the change, kit associated with the change, and a list of serial number machines affected by the change. The type of configuration affected by the change is identified by a product code preceding the serial number.

1.5.2 Introduction (RX)

All significant changes to the machine, which installed in the factory or in the field, are identified by a tag number and a priority letter. They are listed in the Change Tag Index. The priority of change is designated as follows:

Class 1	Modifications must be made in the field immediately if parts are available.
Class 2	Modifications in the field, retrofitted on all machines at the next service call.
Class 3	Repair by replacement of parts and modifications.
Class 4	Modifications performed at discretion of local management or customer's request.
Class 5	Production only

1.6 REFERENCE LIST OF TECHNICAL PUBLICATIONS FOR 820/820-II

1.6 REFERENCE LIST OF TECHNICAL PUBLICATIONS FOR 820/820-II

	<u>MANUAL NAME</u>	<u>VENDOR PART #</u>
1.	820 Training Manual (Xerox Corp)	600P84430
2.	630 Printer OEM Manual (Diablo Systems)	90443-00
3.	630 Printer Service Manual (Xerox Corp)	600P83475
4.	Motorola Monitor Service Manual VP41 (Motorola Corp.)	68P25253A89-0
5.	Ball Monitor Service Manual (Ball Bros.)	5-017-1045
6.	Shugart Disk Controller 1403D OEM Manual (Shugart)	039022-1
7.	Shugart SA1000 Disk Service Manual (Shugart)	039011-0
8.	Shugart SA850 Disk Service Manual (Shugart)	039018-1
9.	Shugart SA800 Disk Service Manual (Shugart)	039025-1
10.	Mostek Z80 MicroComputer Data Book (Mostek Corp)	MK79602
11.	Zilog Z80 Microcomputer Components Data Book	00-2034-01
12.	Zilog Z80 Microcomputer Components Data Book Document Change Notice	E0-2034-01

NOTE: Xerox Corp. only supplies Xerox Publications (600P). All other publications will have to be ordered from the vendors listed above.

INSTALLATION

600P84592

2.1 Preinstall Checkout

2.2 Unpack Machine

2.3 Set Up

2.4 Installation Check List

2.1 PREINSTALL CHECKOUT

1. Check the equipment for damage

NOTE: If the following condition(s) is not corrected, tell your supervisor in writing of the problem.

2. Check the space requirements (Chapter 1, Section 1.2).

WARNING

DO NOT try to correct wiring. If the following voltage(s) is not within specification, tell customer not to connect machine to outlet and have a licensed electrician correct wiring.

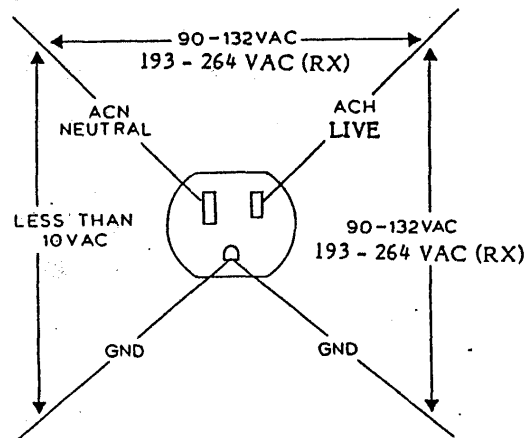

(Figure 2-2)

3. Check the AC Power at outlet (Figure 2-2).
4. Check contents of installation kit.

2.2 UNPACK MACHINE

1. Remove all external packing tape and materials.

2.3 SET UP

1. Ensure power switch is off.
2. Connect keyboard to display/processor.
3. Connect disk drives to display/processor.

WARNING

DO NOT ATTEMPT TO APPLY POWER TO FIXED DRIVE BOX YET: severe damage to the hard disk drive will result.

FIXED DRIVE

1. Remove (2) screws at rear of drive assembly.

NOTE: The long screw in the left side of the box, facing rear, makes the interlock switch when screwed in. When replacing be sure to put it in the left side, facing the rear of the box.

2. Slide top cover to rear, then lift cover off.(Fig. 2-1)

3. With the top cover removed the two disk drives should now be exposed. The fixed drive is the outermost with the floppy drive between it and the Power Supply. As you stand facing the left-hand side of the unit (outer case of hard disk), note the circular aperture in the hard disk's cage, exposing an aluminum spindle hub (Figure 2-1). A fingered flange is inserted into a hole in this spindle hub. The fingered flange is a shipping restraint, called a spindle lock, which MUST be removed before power is applied to unit.

WARNING

After removal of the spindle lock (step 5), be extremely careful when attempting to move the system. The fixed disk drive is extremely delicate and can be severely damaged if bumped or jolted. ALWAYS replace the spindle lock if you are going to move the system more than a few feet. After removal of spindle lock, the spindle hub may be manually rotated, but ONLY in the CLOCKWISE direction. The read/write heads have slight chamfer, and counterclockwise motion could cause them to gouge the media.

4. Verify correct Jumper and Switch settings on Fixed Controller PWA, on 10 MB Controller PWA, and on Floppy Controller PWA. (See Repair Data Fixed Disk Assembly Adjustments 3.5.8.)

5. Unscrew and remove the spindle lock. Invert it so the protruding finger faces outwards towards you, then screw it in this position (finger facing out) to the disk drive case in order not to lose it.(Fig. 2-1)

6. When you have inverted the spindle lock, walk around behind the unit again. A white translucent jack (Figure 2-1) mounted in a metal standoff will be visible from the rear of the Winchester disk drive. This is a AC cable jack. A plug which obviously mates to this jack should also be visible at the end of a cable running from the rear of the floppy disk drive. Press the plug into the Winchester drive jack, making certain they are securely mated.(Fig. 2-1)

7. Remove the cardboard shipping insert from within the floppy disk drive. It has been inserted between the heads to protect them during shipment.

8. Make certain that there is a Winchester media error map printout within the plastic pouch attached to the disk drive bubble. This information is very important; it will be used as backup hardcopy in event the flaw map information already on the disk is inadvertently destroyed.

9. Replace the top cover Do the reverse of removing the top cover, (Fig. 2-1). The long interlock screw should be placed in the left hand hole of the top cover when viewed from the rear.

10. Connect power cord(s) to AC outlet.

NOTE: There is an AC outlet at the rear of the 8' and Fixed Disk Drives that is live when power or switch on the drives is turned on. The printer or processor can be plugged into it.

11. Verify system operation by running system diag.(chapter 6)

8" Floppy Disk Drive

1. Remove Top Disk Cover.
2. Verify correct Jumper settings on the Floppy Controller PWA. (See Repair Data 8" Disk Drives 3.4.2.)
3. Replace Top Disk Cover.
4. Remove the cardboard shipping insert from within the drive. It has been inserted between the heads to protect them during shipment.
5. Connect power cord(s) to AC outlet.
6. Verify system operation by running system diag.(chapter 6)

NOTE: There is an AC outlet at the rear of the 8" drives that is live when the power on switch on the drives is turned on. The printer or processor can be plugged into it.

Printer

1. Connect Signal Cable to Processor.
2. Select Baud Rate for 1200.

NOTE: If installing 630 printer, use P-1/1730/630 Printer Service Manual, and set switches on HPRO5 PWA as shown in fig. 2-3.

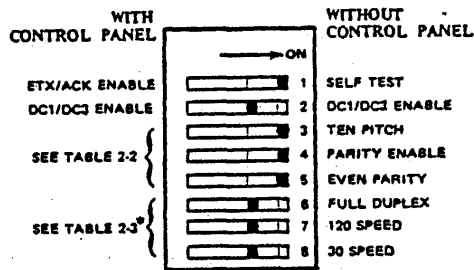

*Switches 6, 7 and 8 are overridden if a keyboard is installed.

Table 2-2
OPTIONAL BAUD RATE SELECT

SWITCH			BAUD
3	4	5	
OFF	OFF	OFF	150
ON	OFF	OFF	600
OFF	ON	OFF	1800
ON	ON	OFF	2000
OFF	OFF	ON	2400
ON	OFF	ON	4800
OFF	ON	ON	7200
ON	ON	ON	9600

Table 2-3
LANGUAGE SELECT

SWITCH			PRINT WHEEL SELECT
6	7	8	
OFF	OFF	OFF	DEFAULT TWP
ON	OFF	OFF	TWP
OFF	ON	OFF	LOGICAL BIT PAIRED
ON	ON	OFF	APL
OFF	OFF	ON	FRENCH AZERTY
ON	OFF	ON	GERMAN
OFF	ON	ON	SCANDINAVIAN
ON	ON	ON	NORSK

(Figure 2-3) 1730/630 HPRO5 Control Switch Functions

3. Connect power cord to AC outlet.

2.4 INSTALLTION CHECK LIST

1. PREINSTALL CHECKOUT
 - ___ Shipping damage.
 - ___ Space requirements.
 - ___ AC power at outlet.
 - ___ Installation Kit contents.
2. UNPACK MACHINE
 - ___ Remove tape and materials.
3. SET UP
 - ___ Power OFF.
 - ___ Connect keyboard.
 - ___ Connect disk drives.
 - ___ Connect power cord(s).
 - ___ Install printer.
4. OPERATIONAL/SYSTEM CHECK
 - ___ Perform the Level 1 Check Procedure (Chapter 6).

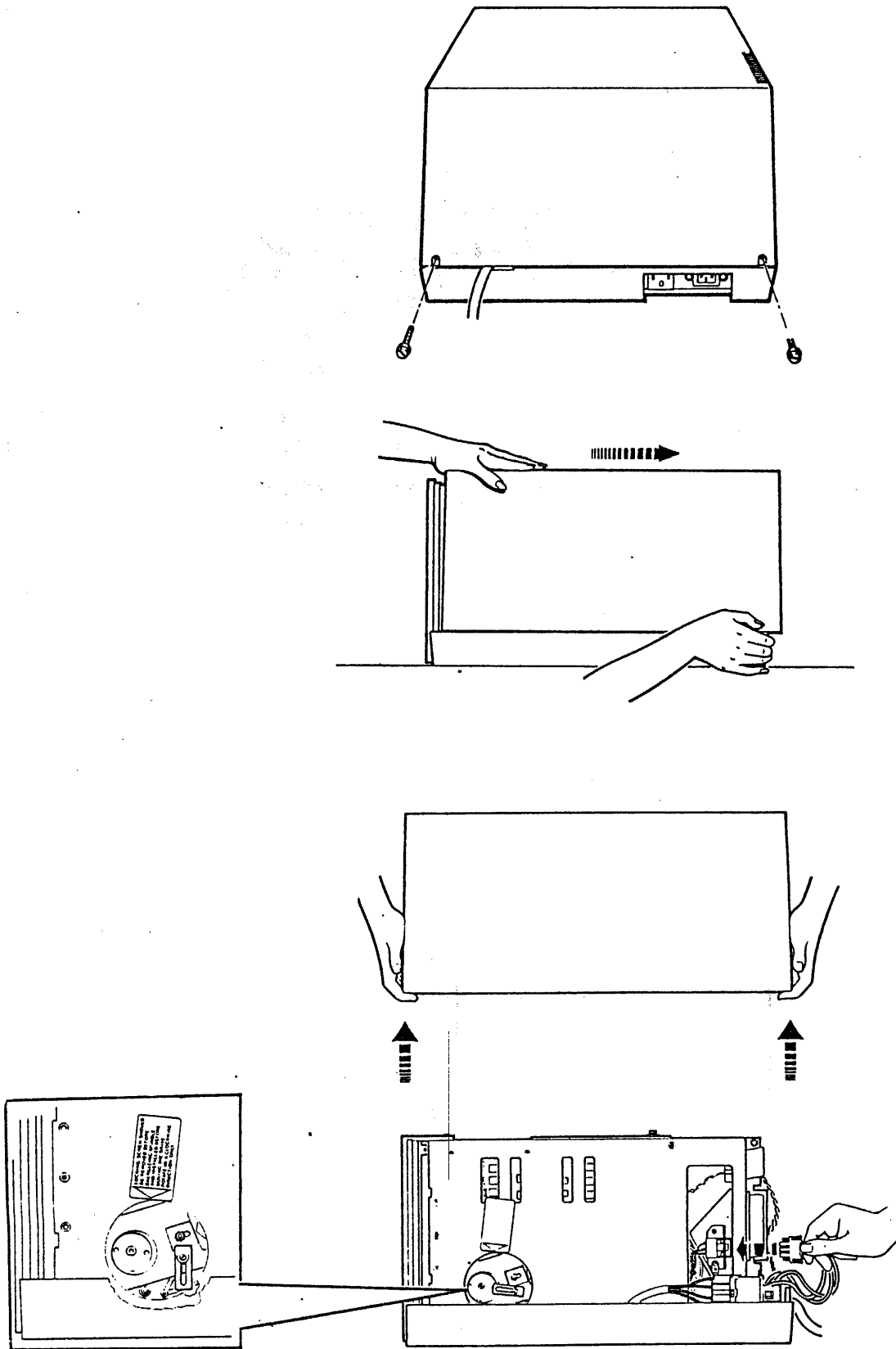

Figure 2-1 Fixed Drive Assembly (8")

REPAIR DATA

3.0 REPAIR DATA

3.1 CRT Assembly

600P84592

Note: The CRT must be turned 90° clockwise while placing it in front of assembly to relieve any strain on high voltage lead.

7. Carefully place CRT on it's face in front of assembly.
8. Remove (4) screws from CRT PWA and remove PWA.

B. REPLACEMENT

WARNING

DO NOT strike, nick, scratch or subject the CRT to any undue pressure. The CRT may implode.

1. Disconnect P102 and P103 from CRT PWA (Ball Monitor only).
2. Disconnect grounding springs from CRT bracket and separate springs (Ball Monitor only).
3. Carefully place CRT in front of assembly with the CRT anode towards the left.
4. Install CRT PWA and place grounding spring toward back of assembly.
5. Connect green ground strap on screw (Motorola only).

NOTE: The CRT must be turned 90° counter clockwise while installing CRT.

6. Carefully install CRT.
7. Connect grounding springs to CRT bracket (Ball Monitor only).
8. Connect P102, P103 and J1 to CRT PWA Ball Monitor only).
9. Connect power cord to wall outlet.
10. Perform adjustment procedure.

C. ADJUSTMENT

Purpose: To obtain the correct size, centering and brightness of the viewing screen.

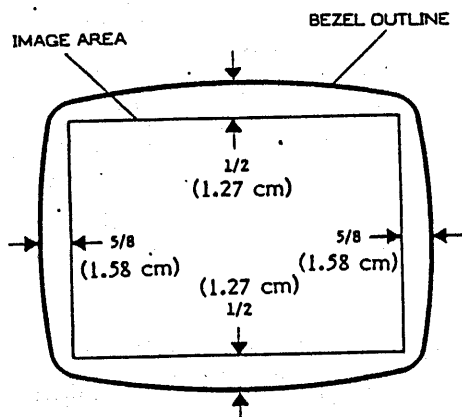
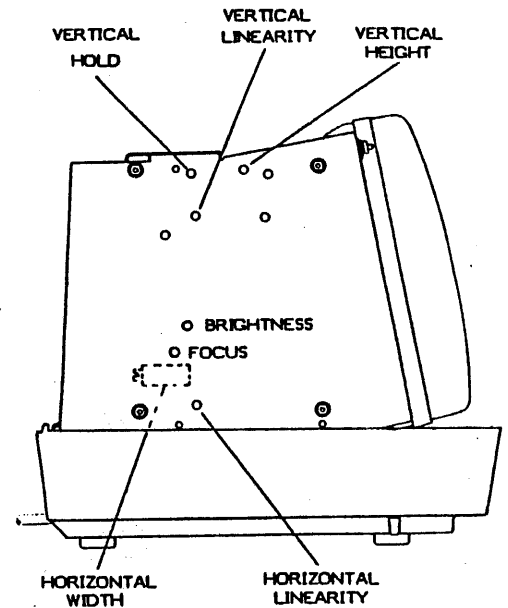

Figure 3-4 DISPLAY ALIGNMENT

Checkout Procedure: Load diagnostic exerciser disc in drive A and an initialized disc in drive B, type A and press RETURN. When X's fill the screen, press CTRL and type S. Using figure 3-4 check alignment

1. Mark the bezel outline on CRT face with a felt tip/grease pencil.
2. Remove top cover (3.1.1).
3. Turn power on.
4. Load diagnostic exerciser disc in Drive A and an initialized disc in Drive B, type A and press RETURN.
5. When X's fill screen, press CTRL and type S.



Ball

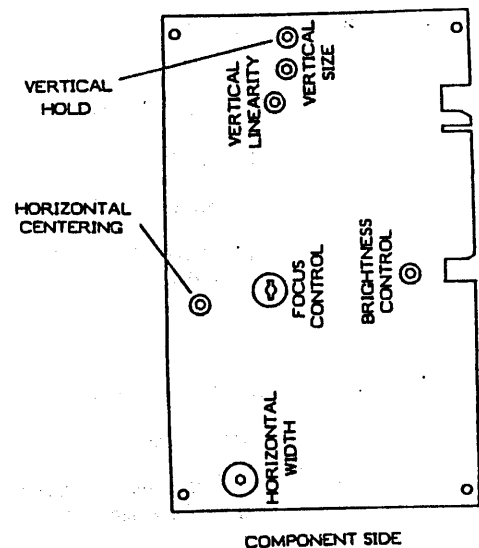

COMPONENT SIDE

Motorola

Figure 3-5 DISPLAY ADJUSTMENT

3.1 DISPLAY/PROCESSOR

3.1.1 DISPLAY/PROCESSOR COVER(S)

A. REMOVAL

WARNING

High voltage exists on CRT. Remove all jewelry. Use extreme care when working on or around CRT.

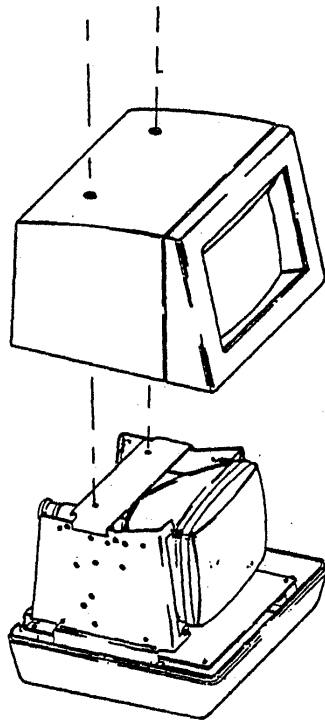

Figure 3-1 REMOVE TOP COVER

1. Turn Power OFF and remove power cord.
2. Remove (2) top cover screws.
3. Lift up top cover to remove.

B. REPLACEMENT

1. Place top cover on display/processor.
2. Install (2) top cover screws.

3.1.2 CRT AND PWA

A. REMOVAL

1. Disconnect power cord from wall outlet.
2. Remove top cover (3.1.1).

WARNING

Do not strike, nick, scratch or subject the CRT to any undue pressure. The CRT may implode.

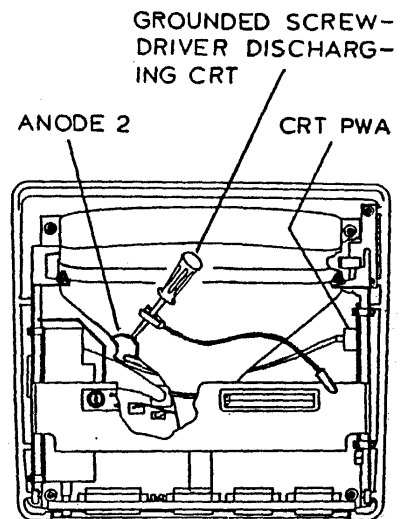

Figure 3-2 DISCHARGE CRT

3. Discharge high voltage on CRT (anode 2) shorting to frame. This is done by using meter lead, alligator clip, and screw driver as shown in fig. 3-2.
4. Disconnect P102, P103 and J1 from CRT PWA (Ball Monitor only).
5. Disconnect grounding springs from CRT bracket and separate springs. (Ball Monitor only).

WARNING

DO NOT strike, nick, scratch or subject the CRT to undue pressure. The CRT may implode.

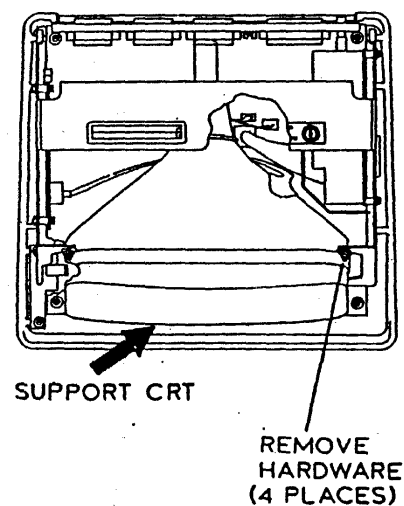

Figure 3-3 REMOVE CRT

6. While supporting the CRT, remove hardware from bracket.

3.0 REPAIR DATA

3.1.4 Main/Processor PWA

600P

3.1.4 MAIN/PROCESSOR PWA (Continued)

820 PROCESSOR (CPU) PWA SHUNT CONFIGURATION

REF.	BETWEEN PINS
E1	1 & 2
E2	1 & 2
J9	7 & 8
	11 & 12
	15 & 16
	19 & 20
	23 & 24
	27 & 28
	31 & 32
J10	3 & 4
	7 & 8

820-II PROCESSOR (CPU) PWA SHUNT CONFIGURATION

REF.	BETWEEN PINS
E1	1&2
E2	1&2
E4	1&2
E6	2&3
E7	1&2
J9	7&8
	11&12
	15&16
	19&20
	23&24
	27&28
J10	3&4
	7&8

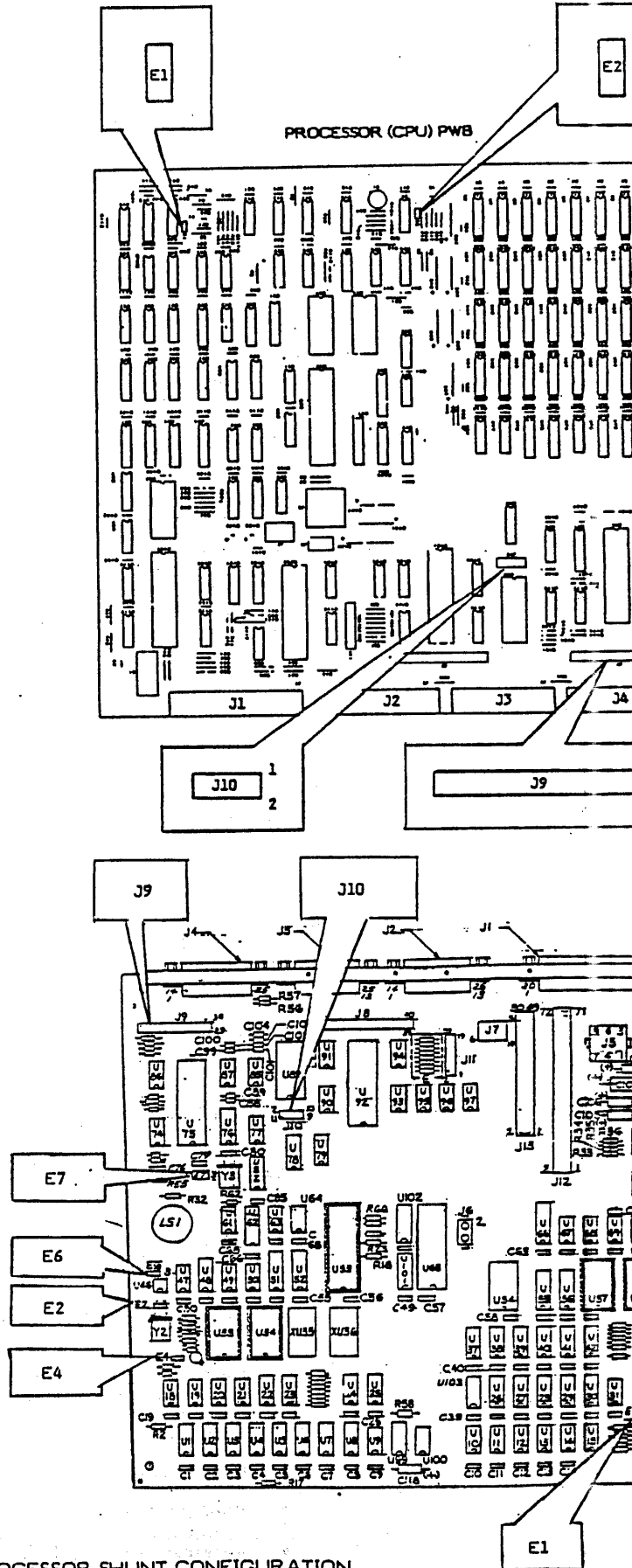

Figure 3-8 PROCESSOR SHUNT CONFIGURATION

6. Position brightness slide control for maximum brightness. Adjust brightness control on the CRT PWA until the raster is visible.
7. Alternately adjust the horizontal width and horizontal linearity/centering until the X's on both sides of the CRT are within 5/8" of the bezel outline (figure 3-4).
8. Alternately adjust the height/size and vertical linearity until the X's on top and bottom of the CRT are within 1/2" (1.27 cm) of the bezel opening (figure 3-4).
9. Adjust vertical hold to center of adjustment range.
10. Position brightness slide control until raster is not visible.
11. Adjust the focus control until the edges and center of the display image is in focus.
12. Dress high voltage lead down, towards processor PWA, and the yellow cathode lead, towards top of assembly.
13. Clean face of CRT and install top cover (3.1.1).

3.1.3 POWER SUPPLY

A. REMOVAL

1. Remove top cover (3.1.1).
2. Disconnect P1 from the power supply and P2 from the processor PWA.

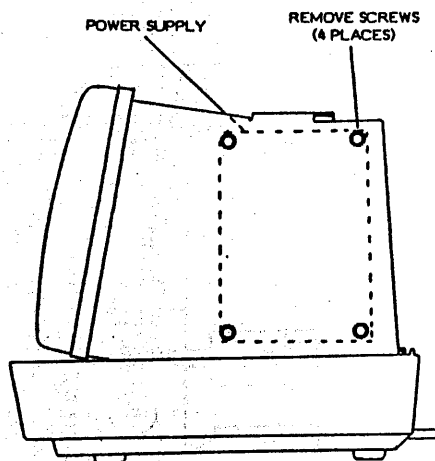

Figure 3-6 REMOVE POWER SUPPLY

3. Remove (4) power supply screws from the CRT frame and remove power supply.

B. REPLACEMENT

1. Install power supply and replace (4) screws.
2. Connect P1 and P2.
3. Install top cover (3.1.1).

3.1.4 MAIN/PROCESSOR PWA

A. REMOVAL

1. Remove top cover (3.1.1).
2. Disconnect all connectors from back display/processor. (Fig. 3-18)

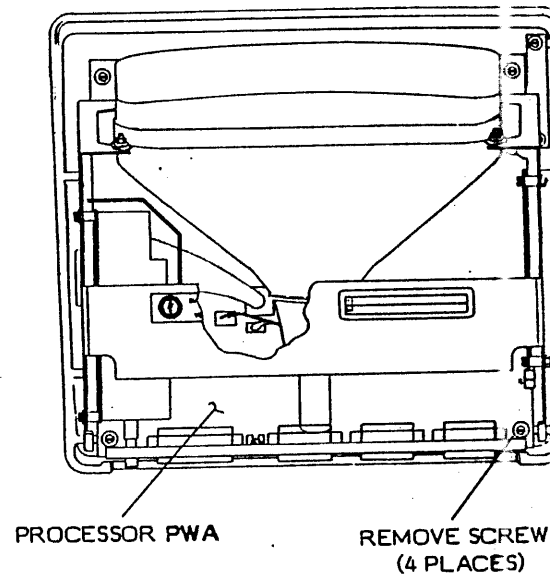

Figure 3-7 PROCESSOR PWA REMOVAL

3. Using a meter lead and alligator clips, screw driver to CRT frame.
4. Discharge high voltage on CRT (anode shorting to frame. (fig. 3-2)
5. Disconnect P5, P6, P7 and spade lug the processor PWA
6. If 820/820-II then remove (2) attaching support block for Daughter PWA. Remove Daughter PWA from processor.
7. Remove (4) screws from the processor and remove by sliding out of the processor.

B. REPLACEMENT

NOTE: Before installing the processor PWA, ensure the shunt configuration is correct (Figure 3-8).

1. Install processor PWB and (4) screws.
2. If 820/820-II replace Daughter PWA support block.

NOTE: Daughter PWA is not keyed. Match on daughter PWA with pin 1 on connector.

3. Connect P5, P6, P7 and spade lug processor PWA.
4. Connect all connectors to the back of processor.
5. Install top cover (3.1.1).

3.2.2 KEYBOARD PWA

A. REMOVAL

1. Remove keyboard cover (3.2.1).

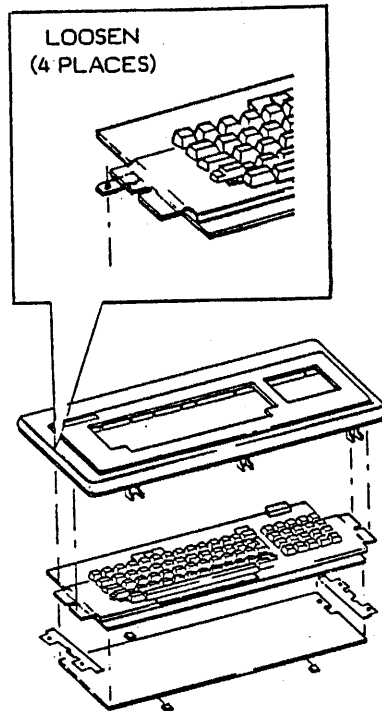

Figure 3-11 REMOVE KEYBOARD PWA

2. Remove (4) screws securing keyboard and brackets in place.
3. Remove keyboard, shield, and brackets.

B. REPLACEMENT

1. Install shield.
2. Put keyboard in top cover ensuring alignment tabs are positioned in keyboard bracket cutouts.
3. Position locking tabs over brackets and tighten screws.
4. Install keyboard cover.

3.2.3 KEYBOARD HARNESS ASSEMBLY

A. REMOVAL

1. Turn power off.
2. Disconnect keyboard harness from display/processor.
3. Remove keyboard cover (3.2.1).

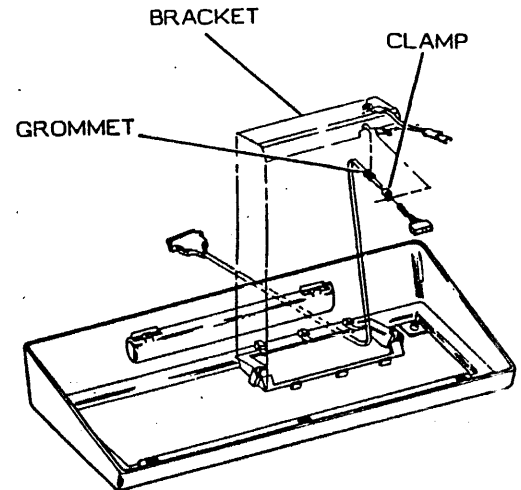

Figure 3-12 REMOVE HARNESS

4. Release locking tabs from harness asser bracket and remove assembly.
5. Remove harness clamp and grommet.

B. REPLACEMENT

1. Install harness clamp and grommet.

CAUTION

Grommet must be inserted in bracket cutout damage to the harness will occur.

2. Install harness on bracket insuring grommet is in bracket cutout.
3. Install harness assembly in bottom cover.
4. Install keyboard cover (3.2.1).
5. Connect keyboard harness to display processor.

3.1.5 Power ON/OFF Switch 3.1.6 Brightness Control 3.2 Keyboard

3.1.5 POWER ON/OFF SWITCH

A. REMOVAL

1. Disconnect power cord from wall outlet.
2. Remove top cover (3.1.1).
3. Remove main/processor PWA(3.1.4).
4. Disconnect wires from terminals 1 and 2 of the power on/off switch.
5. Remove switch.

B. REPLACEMENT

1. Install switch and connect wires to terminals 1 and 2.
2. Install main/processor PWA (3.1.4).
3. Install top cover (3.1.1).
4. Connect power cord to wall outlet.

3.1.6 BRIGHTNESS CONTROL

A. REMOVAL

1. Remove top cover (3.1.1).
2. Remove main/processor PWA (3.1.4).
3. Remove knob from brightness control lever by pulling down on knob.
4. Disconnect P1 from brightness control.
5. Remove (2) screws from brightness control and remove.

B. REPLACEMENT

1. Install brightness control and (2) screws.
2. Connect P1 to brightness control.
3. Install brightness control knob.
4. Install main/processor PWA(3.1.4).
5. Perform brightness adjustment (3.1.2C).
6. Install top cover (3.1.1).

3.2 KEYBOARD

3.2.1 KEYBOARD COVER(S)

A. REMOVAL

1. Turn power off.

CAUTION

When releasing locking tabs, if pressure is not applied directly above tabs, they may break.

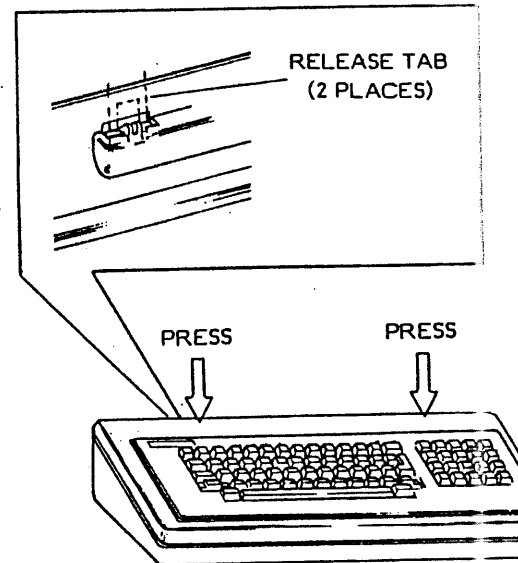

Figure 3-9 REMOVE COVER

2. Press on cover above locking tabs and tabs.

CAUTION

The keyboard harness and grounding wire must be connected before removing top cover and keyboard.

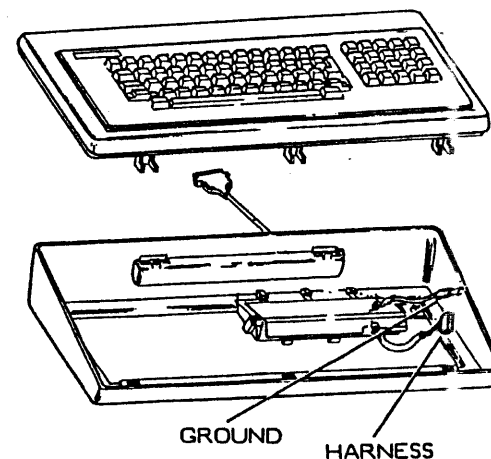

Figure 3-10 DISCONNECT CABLE(S)

3. Lift back of top cover, disconnect keyboard harness and grounding wire.
4. Remove top cover and keyboard.

B. REPLACEMENT

1. Connect keyboard harness and ground wire.
2. Insert front tabs of keyboard.
3. Press on cover above locking tabs and tabs.

3.3 DISK DRIVE ASSEMBLY (5.25")

3.3.1 DISK COVER(S)

A. REMOVAL

1. Turn power off.
2. Disconnect disk drive harness from display/processor.

NOTE: In the following step, protect top cover from damage.

3. Turn disk drive over to allow removal of the cover mounting screws.

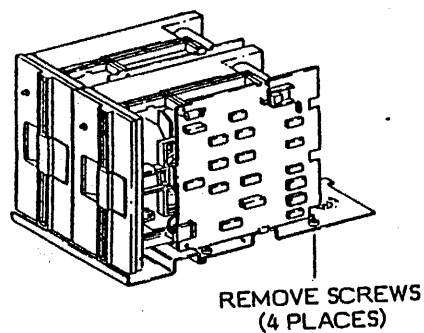
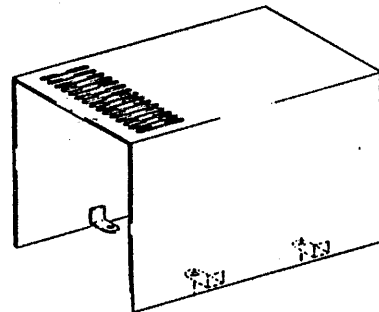

Figure 3-13 TOP COVER REMOVAL

4. Remove (4) top cover screws and remove cover.

B. REPLACEMENT

1. Install drive assembly in top cover.
2. Install (4) top cover screws.
3. Connect drive assembly to display/processor.

3.3.2 DISK DRIVE

A. REMOVAL

1. Remove top cover (3.3.1).
2. Disconnect P1 and P2 from disk drive PWA

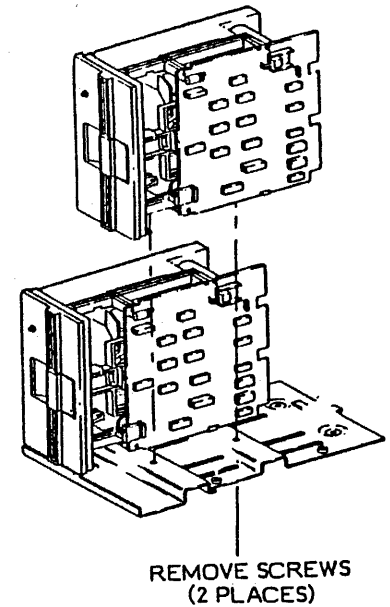

Figure 3-14 DISK DRIVE REMOVAL

3. Remove (2) disk drive screws and remove drive.

B. REPLACEMENT

NOTE: The left disk drive must be confirmed before installing.

1. Position disk drive under bottom cover.
2. Install (2) disk drive screws.
3. Connect P1 and P2.
4. Install top cover (3.3.1).

C. ADJUSTMENT

Purpose: To strap the left drive for physical drive A and the right drive for physical drive B.

Checkout Procedure: Load the system/disc from drive A and check operation.

3.0 REPAIR DATA

3.3.3 Head Load Pad 3.3.4 Disk Drive Belt

600P84592

3.3.2 DISK DRIVES (S)

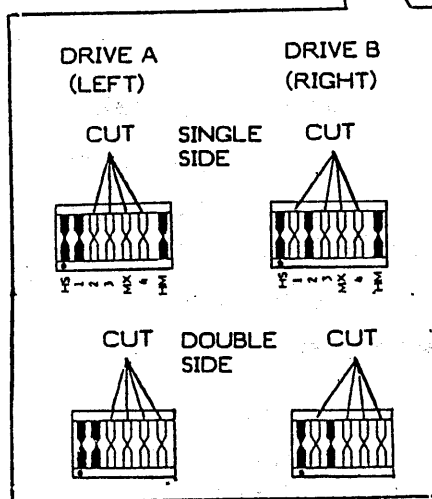
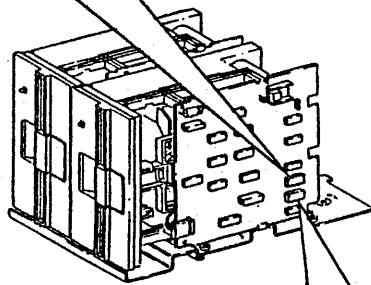
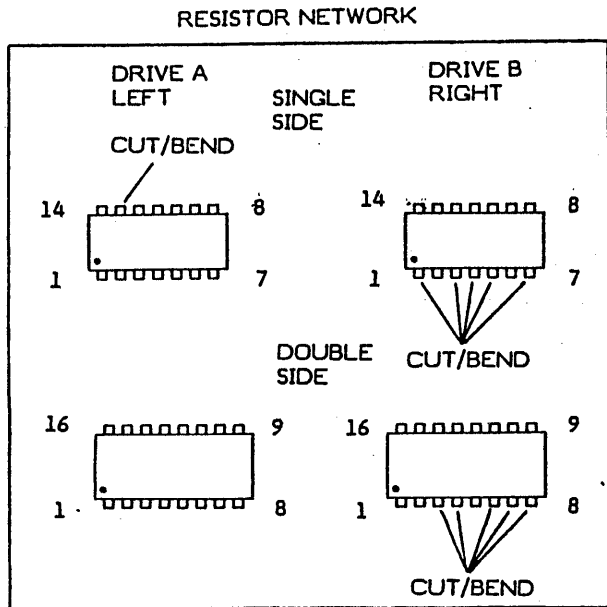

Figure 3-15 DISK DRIVE

1. Configure program shunt by cutting shunts as shown in drawing.
2. Configure resistor network as shown in drawing.

3.3.3 HEAD LOAD PAD

A. REMOVAL

1. Remove top cover (3.3.1).

NOTE: To remove load button on left disk drive remove drive before proceeding.(3.3.2)

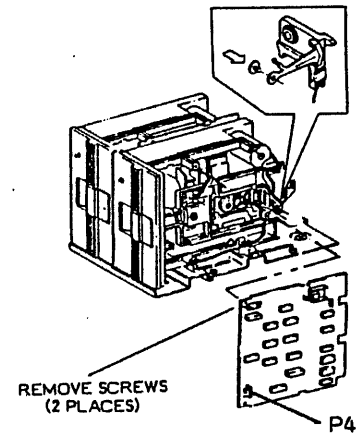

Figure 3-16 HEAD LOAD PAD REMOVAL

2. Disconnect P1, P2, P4 and remove (2) screws from disk drive PWA
3. Remove PWA from bracket and move to right side of drive.
4. Hold load arm away from head, squeeze locking tabs together with needle nose pliers and press forward.

B. REPLACEMENT

1. Press head load pad into load arm from the right side. Inspect and clean head if necessary.
2. Install drive PWA.
3. Install top cover (3.3.1).

3.3.4 DISK DRIVE BELT

A. REMOVAL

1. Remove top cover (3.3.1).

NOTE: To remove drive belt from right drive, remove drive before proceeding.(3.3.2)

2. Remove drive belt.

B. REPLACEMENT

1. Install drive belt with smooth side of belt against pulley.
2. Perform adjustment.
3. Install top cover (3.3.1).

3.4.2 DISK DRIVE(S)

600P84592

3.4.2 DISK DRIVE(S)

A. REMOVAL

1. Remove top cover (3.4.1).
2. Disconnect AC, DC, and signal harness plugs from disk drive.
3. Loosen (2) screws holding front bezel in place and remove bezel.(Fig. 3-20)
4. Remove (2) disk drive screws and remove disk drive.(Fig. 3-20)

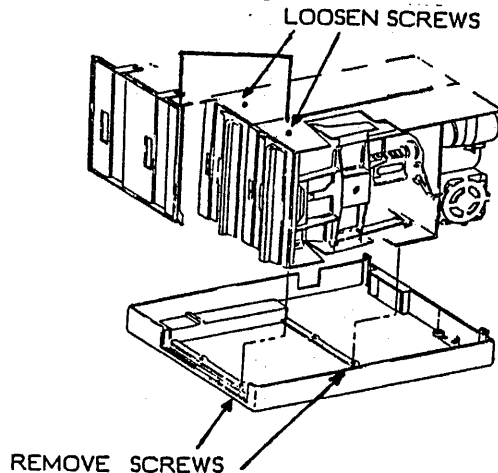

Fig. 3-20 DISK DRIVE REMOVAL

B. REPLACEMENT

NOTE: The right disk drive must be configured before installing.(3.4.2)

1. Position disk drive on bottom cover.
2. Install (2) disk drive screws.
3. Install front bezel .
4. Connect AC, DC, and signal harness plugs to disk drive.

NOTE: When replacing left Disk Drive the clamp holding the AC/DC harness should be replaced also.

5. Install top cover (3.4.1).

C. ADJUSTMENT

1. Replacement disk drive must be jumpered before installation (Fig. 3-21)

NOTE: The disk drive spare may have factory-installed jumpers which are different from those shown in Fig.3-21. Some models of this disk drive will not have jumper pins at location L. A wire has been soldered to accomplish the same function.

2. Refer to Fig. 3-21 and configure jumpers exactly as shown.

- a. Remove any jumpers not shown in Fig. 3-21.
- b. Add any jumpers necessary, as shown in Fig. 3-21.

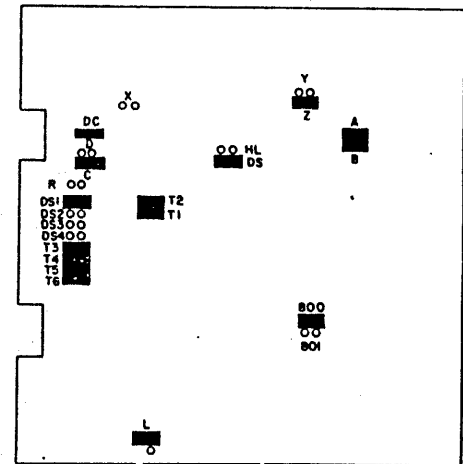

Left Disc Drive

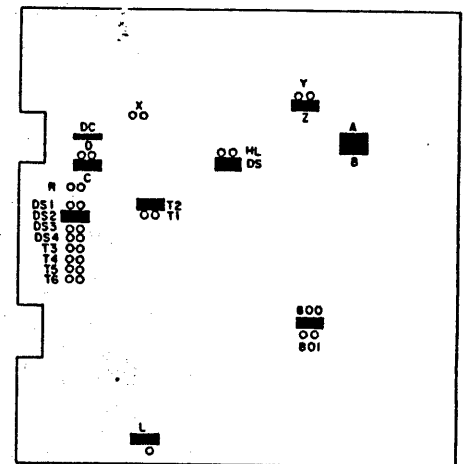

Right Disc Drive

Figure 3-21
SINGLE SIDE
Disc Drive Jumper Locations

C. ADJUSTMENT (Motor Speed)

Purpose: To adjust the disk drive motor for correct operating speed.

Checkout Procedure:

NOTE: When performing the checkout procedure, do not disconnect disk drive harness from display/processor.

- o Remove top cover (3.3.1) and observe the dark lines of the rings on the spindle pulley. The dark lines should appear motionless. The outside ring is 60 HZ and the inside ring is 50 HZ.

NOTE: This adjustment can be made only in an area where there is fluorescent lighting.

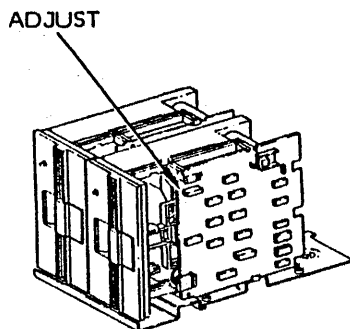

Figure 3-17 DISK DRIVE SPEED ADJUSTMENT

1. Install disk in drive to be adjusted, type A/B press return.

USO

2. Adjust motor speed pot until the dark lines of the outside ring on the spindle pulley appear motionless.

RXO

3. Adjust motor speed pot until the dark lines of the inside ring on the spindle pulley appear motionless.
4. Install top cover (3.3.1).

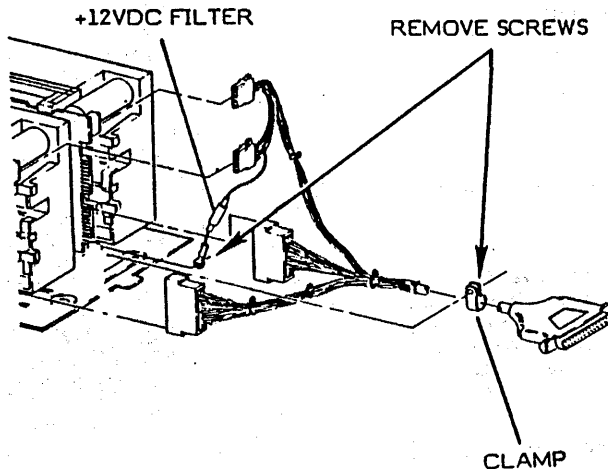

Figure 3-18 DISK DRIVE HARNESS REMOVAL

3.3.5 DISK DRIVE HARNESS

A. REMOVAL

1. Remove top cover (3.3.1).
2. Disconnect P1, P1A, P2 and P2 drives.
3. Disconnect black lead (+12VDC bottom cover).
4. Disconnect and remove harness clamp and save.

B. REPLACEMENT

1. Install restraint clamp over harness.
2. Attach restraint clamp to bottom cover.
3. Attach black lead (+12VDC filter cover).
4. Connect P1, P1A, P2 and P2A to display/processor.
5. Install top cover (3.3.1).
6. Connect disk drive harness to display/processor.

3.4 DISK DRIVE ASSEMBLY (8")

3.4.1 DISK COVER(S)

A. REMOVAL

1. Turn power off.
2. Disconnect P1, P1A, P2 and P2 drives. (Fig. 3-18)

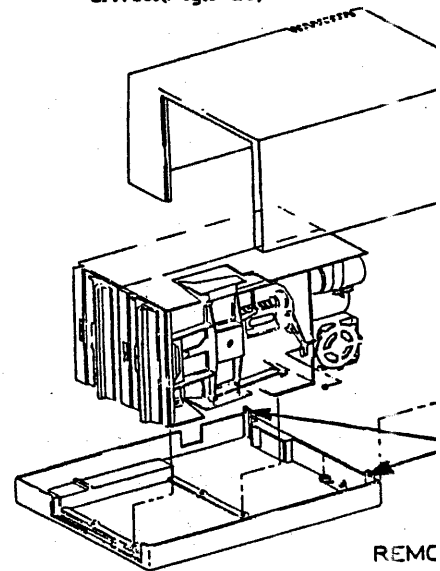
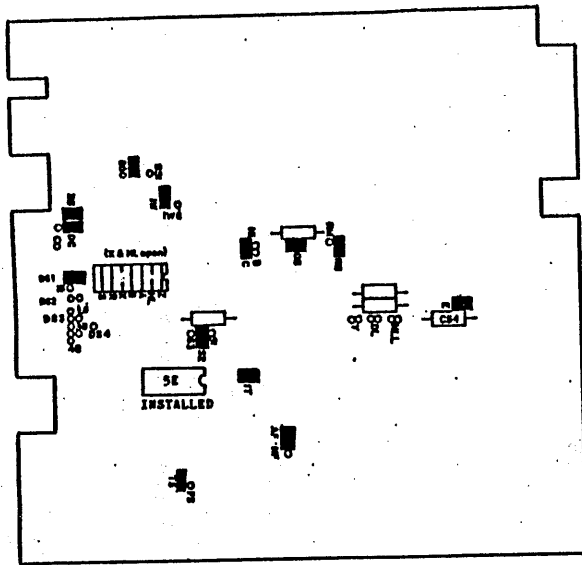

Fig. 3-19 TOP COVER REMOVAL

3. Remove (2) screws at the assembly (Fig. 3-19), slide cover rear, then lift top cover off.

B. REPLACEMENT

1. Install top cover on Drive assembly.
2. Slide cover towards the front.
3. Install (2) rear cover screws.
4. Connect drive assembly to display/processor.



Left Disc Drive

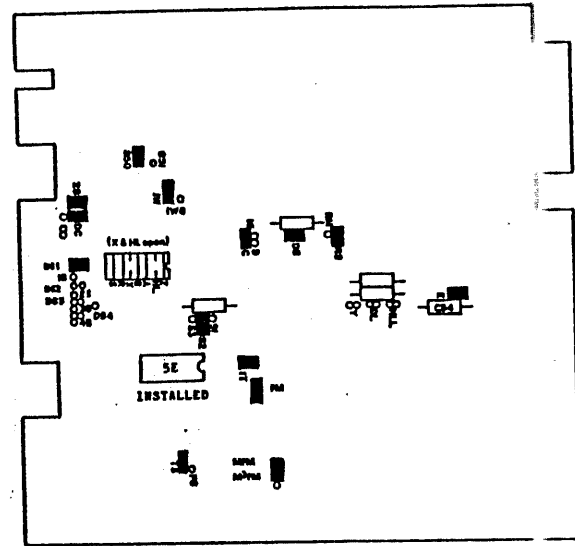

Left Disc Drive

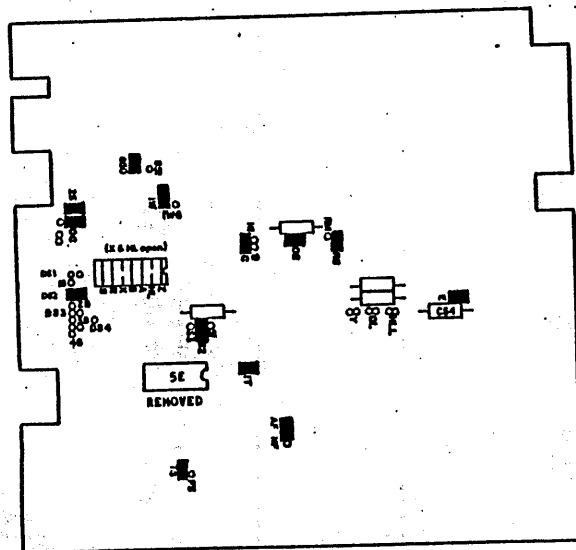

Right Disc Drive

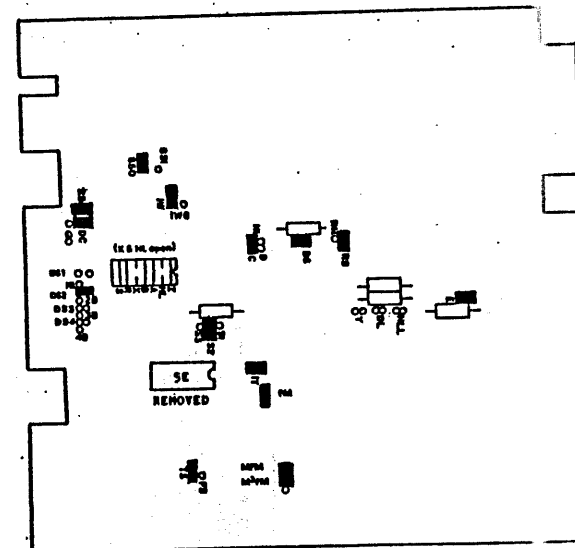

Right Disc Drive

Figure 3-21
DOUBLE SIDE/MLC 12 PWA
Disc Drive Jumper Locations

Figure 3-21
DOUBLE SIDE/MLC 14 PWA
Disc Drive Jumper Locations

3.4.3 HEAD LOAD PAD, SINGLE SIDE DISK DRIVE

REMOVAL

1. If removing left disc drive load pad, remove top cover (3.4.1) and left disc drive (3.4.2). removing the right disc drive load pad, remove top cover only.
2. Rotate head stepper motor shaft at rear of unit until head assembly is moved forward.
3. Lift and hold head load arm out away from head.(Fig. 3-22)
4. Squeeze locking tabs together with needle nose pliers and press forward to pop out load pad.

600P84592

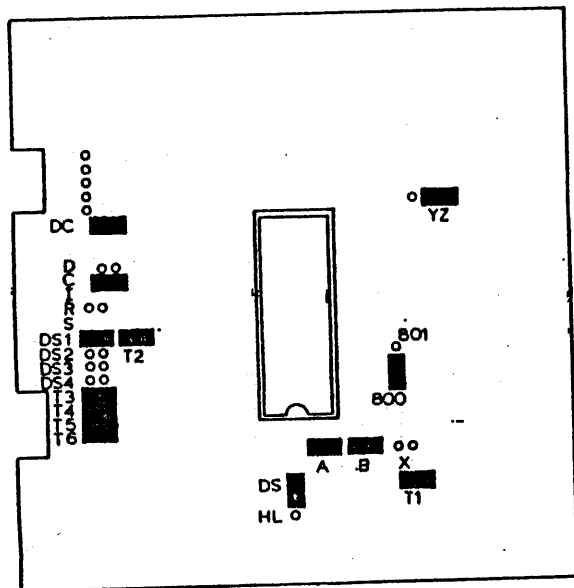

Left Disc Drive

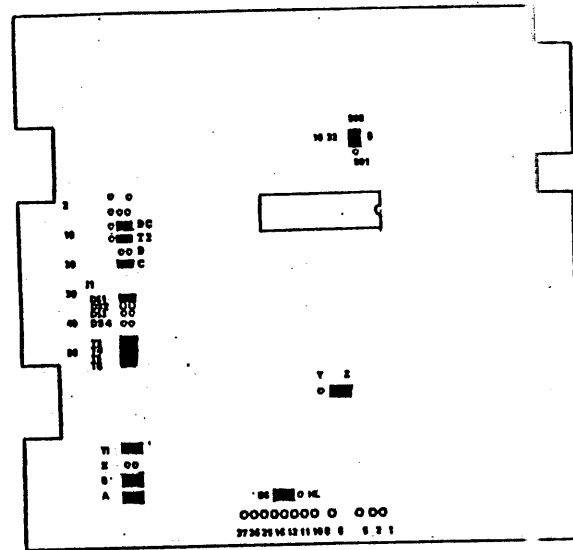

Left Disc Drive

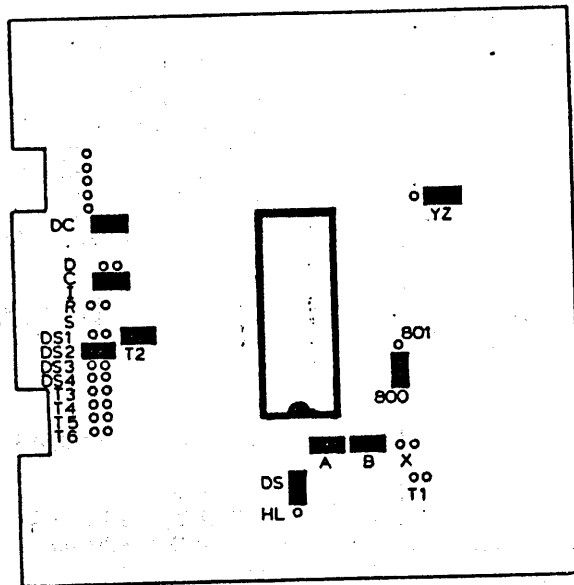

Right Disc Drive

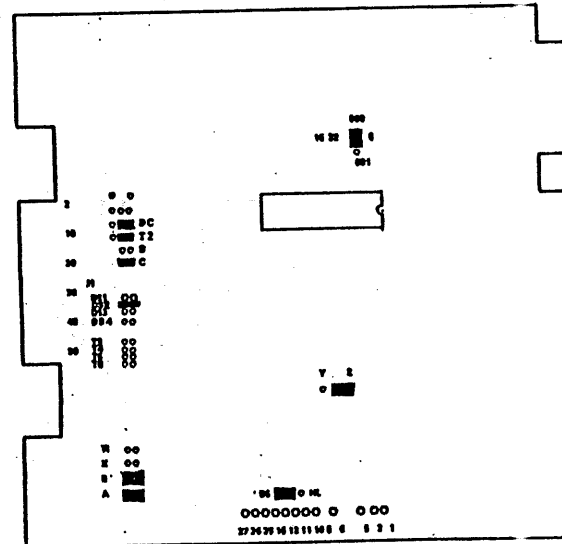

Right Disc Drive

Figure 3-21
SINGLE SIDE w/ LSI CHIP
Disc Drive Jumper Locations

Figure 3-21
SINGLE SIDE w/NEW LSI CHIP CONFIG
Disc Drive Jumper Locations

3.5.2 FIXED DRIVE CONTROLLER PWA

3.5.3 FIXED DRIVE

3.5.4 10 MB CONTROL PWA

3.5.2 FIXED DRIVE CONTROLLER PWA

A. REMOVAL

1. Remove top cover. (3.5.1)
2. Remove (2) screws supporting Controller PWA support bracket to drives. (fig. 3-25)

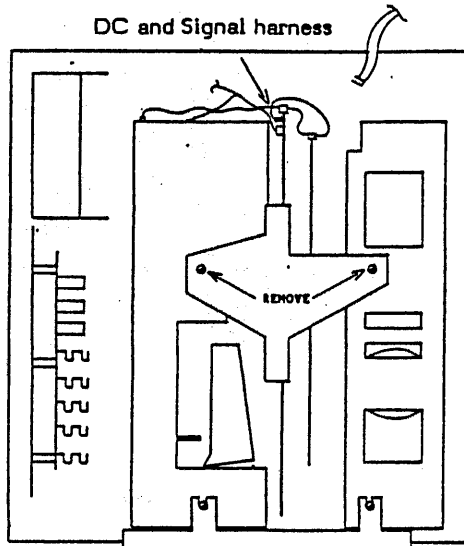

Fig. 3-25 FIXED DRIVE ASSEMBLY

3. Unplug DC and signal harness plugs from Controller PWA.
4. Lift Controller PWA and support out of drive assembly.
5. Remove (5) screws attaching PWA to support.

B. REPLACEMENT

1. Refer to procedure 3.5.8 for switch setting.
2. Fasten Controller PWA to support bracket with (5) screws.
3. Lower PWA and bracket into the slot between floppy drive and fixed drive.(fig.3-25)
4. Attach DC and signal harnesses to 3.5.4 PWA.(fig.3-25)
NOTE: Care should be taken when reinstalling signal harness.
5. Secure bracket with (2) screws to drives.
6. Replace top cover.(3.5.1)

3.5.3 FIXED DRIVE

A. REMOVAL

1. Remove top cover.(3.5.1)
2. Remove Controller PWA.(3.5.2)

3. Secure locking Key into spindle (Fig.3-26)

CAUTION
DO NOT ATTEMPT TO MOVE DRIVE WITHOUT SPINDLE LOCKED DOWN.

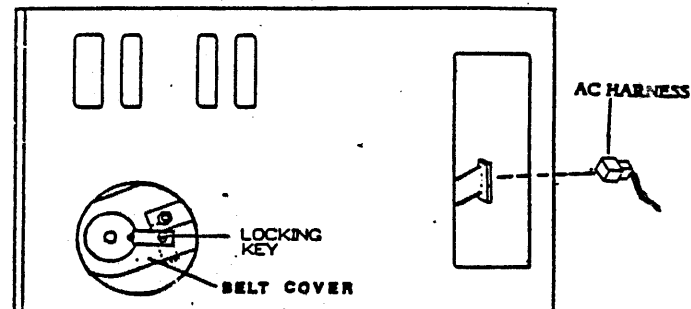

NOTE: Whenever the machine or the fixed drive is moved, the lock key must be put back in place to keep from damaging the drive. When removing the lock key, turn it bottom side up and fasten it to the drive so it can be stored for future use.

Fig. 3-26 FIXED DRIVE SPINDLE LOCK

4. Disconnect AC, DC, and signal harness.
5. Disconnect ground strap from AC connector.
6. Loosen (2) screws securing bezel.(fig. 3-20) and remove bezel.
7. Remove (2) screws securing Fixed Drive to base and remove drive.(Fig.3-20)

B. REPLACEMENT

1. Replace drive onto base and install (2) screws.(Fig.3-20)
2. Install front bezel.(fig.3-20)
3. Connect ground strap, AC, DC, and signal harness.
4. Replace Controller PWA.(3.5.2)
5. Remove locking screw, invert spindle locking key, and attach it to the drive casing.(fig.3-26)
6. Replace top cover.(3.5.1)

10 MB CONTROL PWA

A. REMOVAL

1. Remove top cover (3.5.1).
2. Remove fixed controller PWA (3.5.2).
3. Remove fixed drive (3.5.3).
4. Disconnect J6 through J9 on 10 MB control PWA. (See Figure 3-27).
5. Remove one screw located at top edge of PWA. (Fig.3-27)
6. Unfasten the (3) quarter turn PWA mounts.
7. Remove 10 MB control PWA.

REPLACEMENT

CAUTION
Do not touch the soft pad surface on the load pad. The oil or dirt from fingers can harm the disc surface.

1. Press load pad into arm from head side until it snaps into place.
2. Lightly wipe the read/write head with Clean-ups and allow load pad arm to return to operating position.
3. Replace disk drive, if removed, and verify repair.
4. Replace top cover (3.4.1).
5. Run diagnostics to verify replacement.

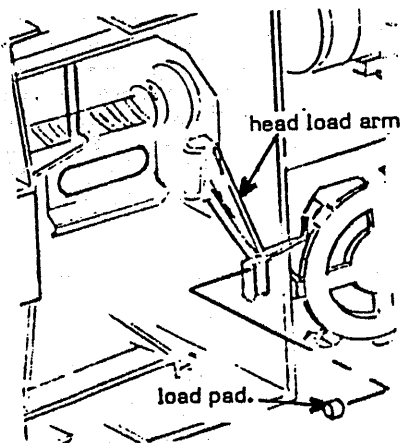

FIG. 3-22 HEAD LOAD PAD REPLACEMENT

3.4.4 8" DISC DRIVE POWER SUPPLY

REMOVAL

1. Turn drive power off.
2. Remove top cover (3.4.1)
3. Remove (4) nuts securing power supply to bracket.(Fig. 3-23)
4. Disconnect P-1 and P-2 from power supply and lift out.

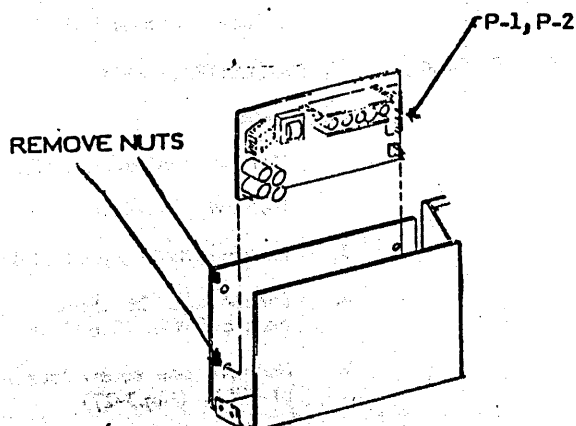

FIG. 3-23 POWER SUPPLY REPLACEMENT

REPLACEMENT

1. Connect P-1 and P-2 to power supply.
2. Secure power supply with (4) nuts to bracket.
3. Check J-5 pins on disk drive board to voltages (Fig. 3-24).
4. Replace top cover (3.4.1).
5. Run diagnostics to check system.

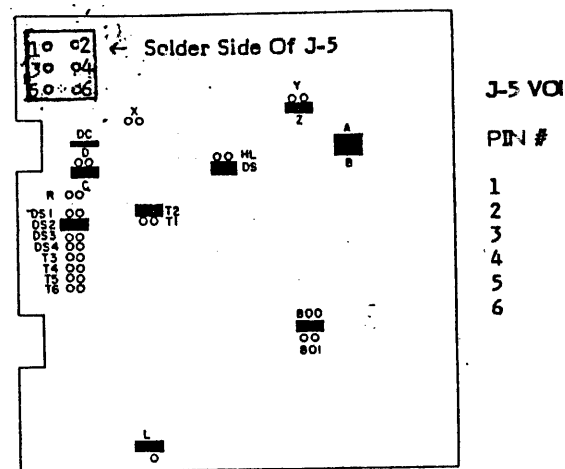

FIG. 3-24 J-5 PLUG ON DRIVE BOARD

3.5 FIXED DRIVE ASSEMBLY

Note: For removal and replacement of 8" floppy fixed assembly reference floppy drive assembly 8" For jumper configuration reference 3.5.8, step 3.

NOTE: For removal and replacement of power the fixed drive assembly, reference 8" disk drive supply 3.4.4.

3.5.1 DISK COVER(S)

A. REMOVAL

1. Turn power off.
2. Disconnect disk drive harness display/processor.
3. Remove (2) screws at the rear of assembly (fig.3-19), slide cover towards then lift cover off.

NOTE: The long screw in the left side (as v from the rear of the unit) of assembly is to the interlock switch. When replacing be st install long screw in left side.

B. REPLACEMENT

1. Install top cover on drive assembly.
2. Slide cover towards front.
3. Install (2) rear cover screws. Facing th of the assembly the long screw goes left side.
4. Connect signal harness to display/processor.

3.5.7 DAMPER ASSEMBLY

9. Loosen and slide capacitor mounting bracket out of way.
10. Note wire color codes connecting to capacitor, then remove wires from capacitor.
11. Remove remaining motor mounting nuts and washers, and remove motor and cable harness.

B. REPLACEMENT

NOTE: If replacing only the belt, perform steps 9 thru 15.

1. Remove motor pulley off of old motor and install onto new motor.
2. Motor pulley should be .035 inch (.88 MM) up off of motor face. (See Figure 3-29). Ensure that one set screw is located on flat side of motor shaft.
3. Mount motor to casting placing an insulating washer on each side of casting on all four posts except the post which the belt cover mounts, no washer is needed on the nut side of that post.
4. Verify center to center distance of 7.74 inches (19.6 cm) from motor shaft to spindle shaft.
5. Reposition motor if necessary to meet center to center spacing and tighten nuts.
6. Replace color coded wires on the noted leads of capacitor.
7. Route wires for rear AC connector and mount in rear bracket.
8. Rotate capacitor securing bracket over capacitor and tighten screw.
9. Replace 10 MB Drive Belt by sliding over pulleys with number of belt on outer side.

CAUTION

Rotating the spindle in a counterclockwise direction will cause severe damage to the heads or media.

10. Replace 10 MB belt cover and securing nut. (Use motor mounting post and nut inside of belt path.)
11. Replace drive spindle lock.
12. Replace 10 MB disc cover and (3) securing screws.
13. Replace fixed disc drive (3.5.3.).
14. Replace fixed controller PWA (3.5.2.).
15. Replace top cover (3.5.1.).

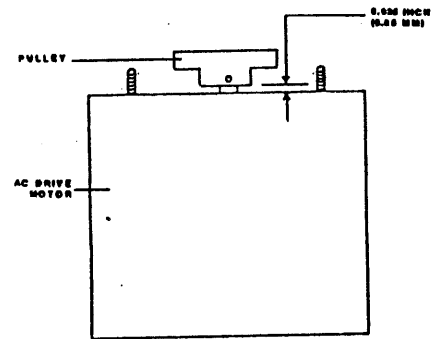

Figure 3-29
10 MB DRIVE MOTOR
Pulley Replacement

3.5.7 DAMPER ASSEMBLY

A. REMOVAL

1. Remove top cover (3.5.1.).
2. Remove fixed controller PWA (3.5.2.).
3. Remove fixed disc drive (3.5.3.).
4. Remove 10 MB disc cover by removing (3) securing screws.

CAUTION

AC power must be applied to drive when removing damper.

CAUTION

Do not turn on system power until spindle locking bracket is removed.

5. Position drive on its side with damper facing up.
6. Remove spindle locking bracket, connect J4 and apply power to fixed disc drive.
7. Remove filler screw from side of damper. (See Figure 3-30).

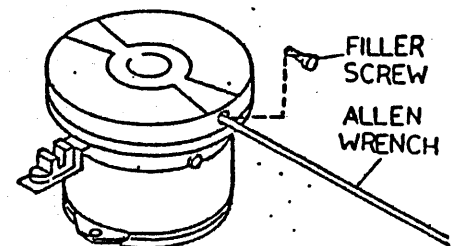

Figure 3-30
DAMPER ASSEMBLY
Removal Procedure

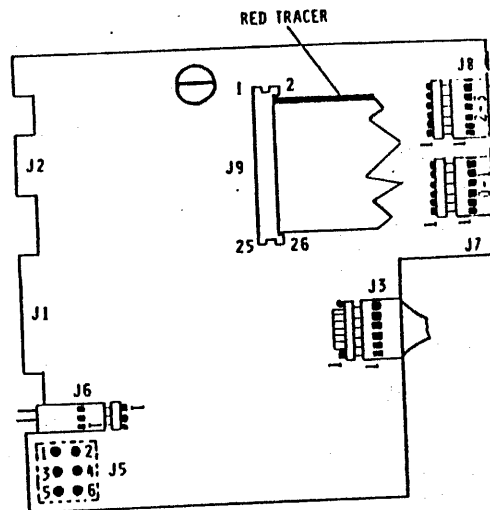

Figure 3-27
10 MB CONTROL PWA

B. REPLACEMENT

1. Refer to procedure 3.5.8, step 2, for jumper settings.
2. Replace 10 MB control PWA.
3. Fasten the (3) quarter turn PWA mounts.
4. Replace one screw located at top edge of PWA.
5. Refer to Figure 3-27 and reconnect J-5 through J-9.
6. Replace Fixed Disc Drive (3.5.3.).
7. Replace fixed drive Controller PWA (3.5.2.).
8. Replace top cover (3.5.1.)

NOTE: On future fixed drive systems the stepper control PWA will be incorporated into a 10 MB control PWA.

3.5.5 10 MB STEPPER PWA

A. REMOVAL

1. Remove top cover (3.5.1.).
2. Remove fixed controller PWA (3.5.2.).
3. Remove fixed drive (3.5.3.).
4. Remove 10 MB disc drive cover by removing (3) screws securing cover to casting.
5. Disconnect flat ribbon connector from stepper PWA. (figure 3-28).
6. Remove (3) screws securing stepper PWA to casting.
7. Remove stepper PWA. (See Figure 3-28).

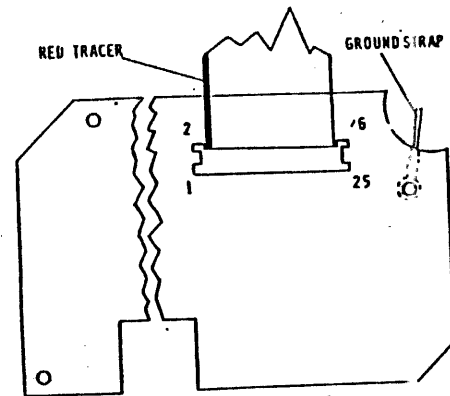

Figure 3-28
10 MB STEPPER PWA

B. REPLACEMENT

1. Replace stepper PWA.
2. Replace ground strap and (3) screw stepper PWA to casting. (Fig. 3-28)
3. Connect flat ribbon connector to s PWA.
4. Replace disc cover and the (3) screws.
5. Replace fixed drive (3.5.3.).
6. Replace fixed controller PWA (3.5.2.).
7. Replace top cover (3.5.1.).

3.5.6 10 MB DISC MOTOR/BELT

A. REMOVAL

1. Remove top cover (3.5.1.).
2. Remove fixed controller PWA (3.5.2.).
3. Remove fixed drive (3.5.3.).
4. Remove 10 MB disc cover by removing (3) screws securing disc cover to casting.
5. Remove spindle locking key

CAUTION

Rotating the spindle in a counterclockwise direction will cause severe damage to heads or media.

6. Remove 10 MB disc belt by removing the (1) nut securing belt to casting.
7. Remove 10 MB disc belt by sliding belt off the motor pulley.
8. Remove AC connector from bracket.

NOTE: Perform steps 8 thru 11 only if using a fixed drive.

3.5.8 FIXED DISC ASSEMBLY ADJUSTMENT

8. Insert a .05 inch (1.27 MM) allen wrench into hole and loosen screw. (See Figure 3-31).
9. Rotate damper 90° and loosen second set screw.
10. Gently remove damper with upward pressure.
11. Replace filler screw.
12. Turn power off.

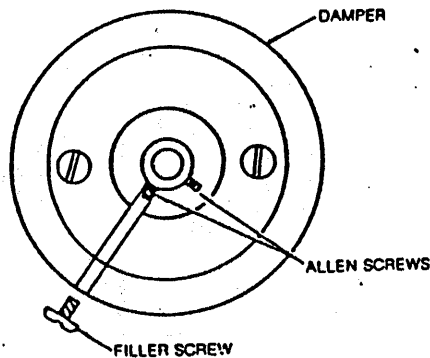

Figure 3-31
DAMPER ASSEMBLY
Screw Locations

B. REPLACEMENT

1. Ensure power is on and J4 is connected.

CAUTION

Do not move damper assembly without AC power applied to fixed disc.

2. Locate and align one set screw with filler hole on replacement damper.
3. Using plier, remove damper plug. (See Figure 3-32).
4. Remove filler screw from side of damper.

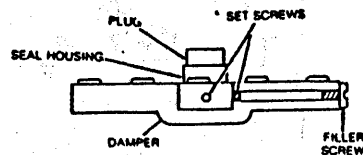

Figure 3-32
DAMPER ASSEMBLY
with Plug

5. Place damper on actuator motor shaft .01 inch (.25 MM) off the track 00 flag collar.
6. Tighten set screw rotate 90° and tighten second set screw. (See Figure 3-33).
7. Replace filler screw.
8. Wipe damper clean.
9. Turn off system power.
10. Replace 10 MB disc cover.
11. Replace fixed disc (3.5.3.).
12. Replace fixed controller PWA (3.5.2.).
13. Replace top cover (3.5.1.).

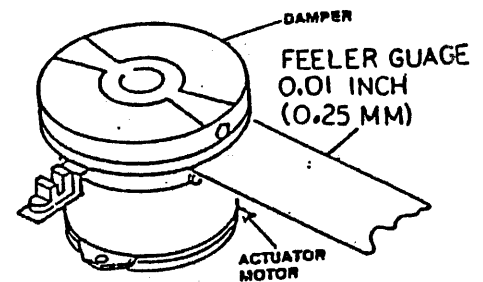

Figure 3-33
DAMPER ASSEMBLY
Replacement Procedure

3.5.8 FIXED DISC ASSEMBLY ADJUSTMENTS

NOTE: For removal and replacement of floppy drive in fixed drive housing reference floppy drive assembly (3.4.2).

NOTE: For removal and replacement of power supply in fixed drive housing reference 8" disc drive power supply 3.4.4.

1. Fixed drive controller PWA switches set before installation.

DIP SWITCH SETTINGS

- A. Switches 2, 3, 5 ON
Switches 1, 4, 6, 7, 8 OFF
Refer to (Figure 3-34).

3.5.9 INTERLOCK SWITCH

A. REMOVAL

NOTE: Interlock switch has AC power going to it. Disconnect AC cord before removal and replacement.

1. Remove top cover (3.5.1)
2. Remove securing screw for interlock switch mounting bracket.
3. Lift interlock bracket out, and disconnect interlock harness from interlock switch at connection J5/P5.
4. Remove interlock switch from interlock bracket.

B. REPLACEMENT

1. Insert interlock switch into interlock bracket.
2. Connect interlock harness to interlock switch. Insure locking insert on the switch mates to locking tab on harness.
3. Replace bracket and install securing screw. Ensure fixed drive ground strap is connected to screw.

C. ADJUSTMENT

1. Placement of mounting bracket must be 1 inch away from top cover screw mounting tab. Tighten securing screw. (Refer to figure 3-27).
2. Replace AC cord.
3. Replace top cover.

NOTE: If no power is observed when system power switch is turned on, check interlock switch mounting bracket alignment.

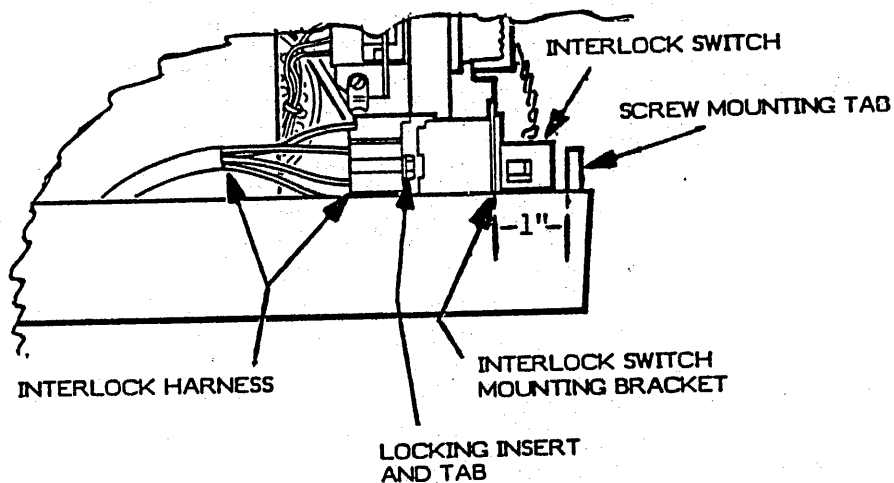

FIG. 3-27 INTERLOCK SWITCH

600P84592

PARTS IDENTIFICATION

4.0 PARTS IDENTIFICATION

PL 4.1 Display Processor

600P84592

ITEM	XEROX PART NO.	(USO)
		DESCRIPTION
1	2S82073	Top Cover Assembly (TSC only)
2	105P80366	Power Supply
3	110P80540	Power On/Off Switch
4	117S80673	Power Cord Assembly (927)
5	117S80724	Power Cord Assembly (U05/U03)
5	123P80103	* Monitor (CRT & PWA)
6	140S82702	Brightness Control PWA
7	140S82628	Processor (CPU) PWA (927)
	140S82828	Processor (CPU) PWA (U03/U05)
8	152S24160	Printer Cable (10 feet)
9	152S81238	Signal Harness
11	601S870	2.0 Rom Kit
12	140S82771	Floppy Drive Interface
13	140S82758	Fixed Drive Interface
15	3P80664	Knob
16	116P80768	Contact Strip-Bottom
17	116P80769	Contact Strip-Top
A	99P3049	Fuse 2.5A (Package of 5)

*The monitor PWA is part of Item 5.

ITEM	XEROX PART NO.	(RXO)
		DESCRIPTION
1	2S82073	Top Cover Assembly
	2S82110	Top Cover Assy FCC Class B
2	105S80383	Power Supply
3	110P80470	Power On/Off Switch
4	117S80697	Power Cord (E 39)
	117S80729	Power Cord (U04/U06/U44/U45)
5	123P80105	* Monitor (CRT & PWA)
	123P80114	* Monitor (Green CRT)(U44/U45)
6	104S82626	Brightness Control PWA
7	104S82755	Processor PWA Tag #2 (E39) (except Germany)
	140S82774	Processor PWA FCC Class B (E39) (Germany on
	140S82777	Processor PWA (U04/U06/U44/U45)
8	152S24160	Printer Cable
9	152S81238	Signal Harness
10	N/A	Data Label
11	— —	2.0 ROM Kit (US)
12	140S82771	Floppy Drive Interface PWA (U04/U06/U44/U45)
13	140S82758	Fixed Drive Interface PWA (U04/U06/U44/U45)
14	2S82072	Bottom Cover
	2S82114	Bottom Cover FCC Class B
15	3P80664	Knob
16	116P80768	Contact Strip-Bottom (U04/U06/U44/U45)
17	116P80769	Contact Strip-Top (U04/U06/U44/U45)
A	708W09501	Fuse 1.25A

*The Monitor PWB is part of Item 5.

(USO)

<u>ITEM</u>	<u>XEROX PART NO.</u>	<u>DESCRIPTION</u>
1	2P29832	Keyboard Top Cover
2	4P80154	Foot
3	91P81375	Logo
4	110S80542	Keyboard Assembly
	110S80564	Keyboard Assembly (Alt.)see note
5	152S81237	Keyboard Harness
9	19P80573	Keyboard Mounting Bracket

NOTE: This keyboard will reduce entry errors associated with typing speed, commonly known as keybounce.

(RXO)

<u>ITEM</u>	<u>XEROX PART NO.</u>	<u>DESCRIPTION</u>
1	2P29832	Keyboard Top Cover
2	4P80154	Foot
3	91P81375	Logo
4	110S80552	Keyboard Assy
5	152S81237	Keyboard Harness
6	91P81574	Product Code Label
7	73S22090	UK English Keycap Kit
	73S22091	French Keycap Kit
	73S22092	German Keycap Kit
	73S22093	Dutch Keycap Kit
	73S22094	Italian Keycap Kit
	73S22095	Swedish/Finnish Keycap Kit
	73S22096	Norwegian/Danish Keycap Kit
	73S22097	Spanish Keycap Kit
	73S22098	ASC II Keycap Kit
	73S22830	Swiss French Keycap Kit
	73S22831	Swiss German Keycap Kit
8	2P82033	Keyboard Bottom Cover
9	19P80573	Keyboard Mounting Bracket

600P84592

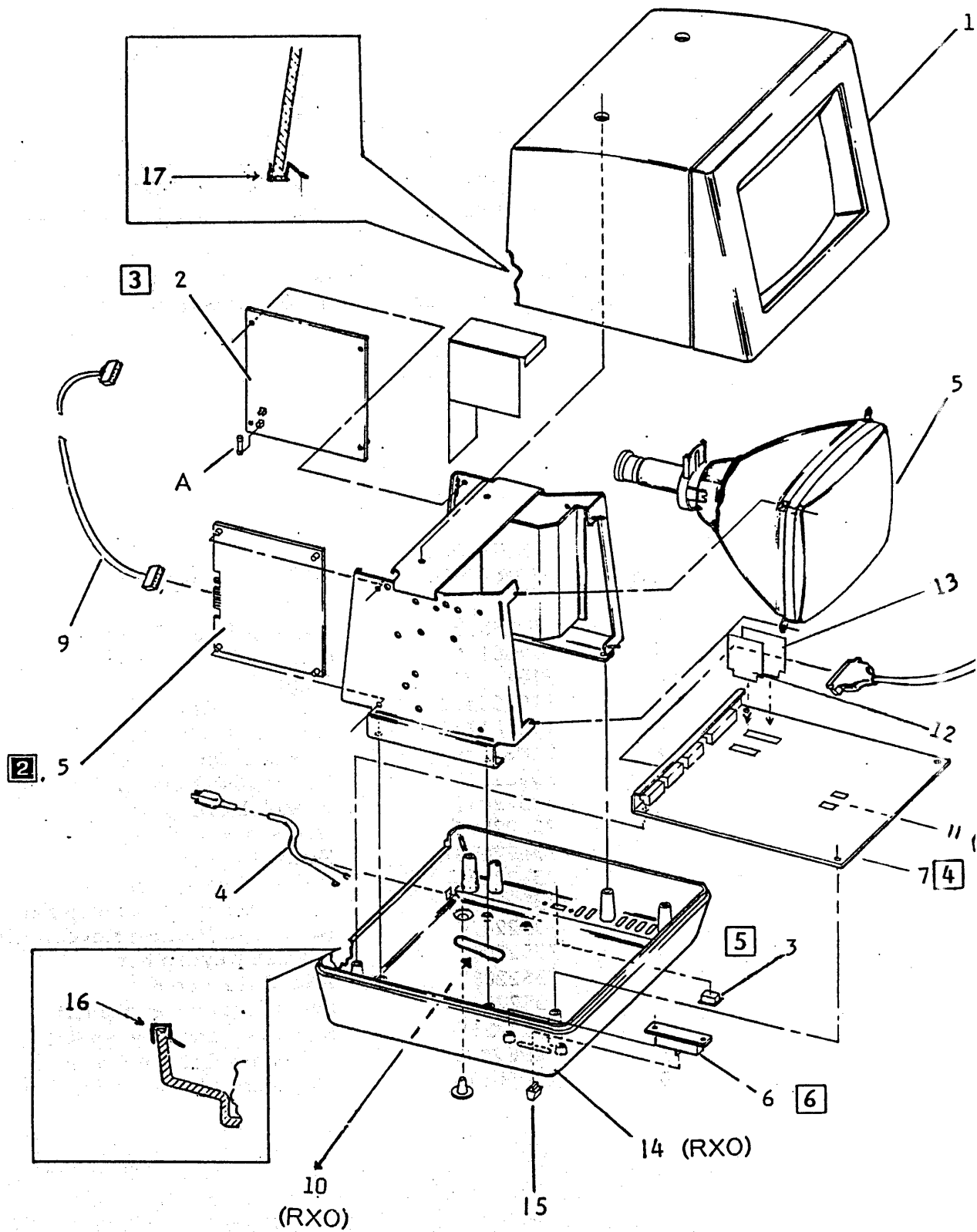

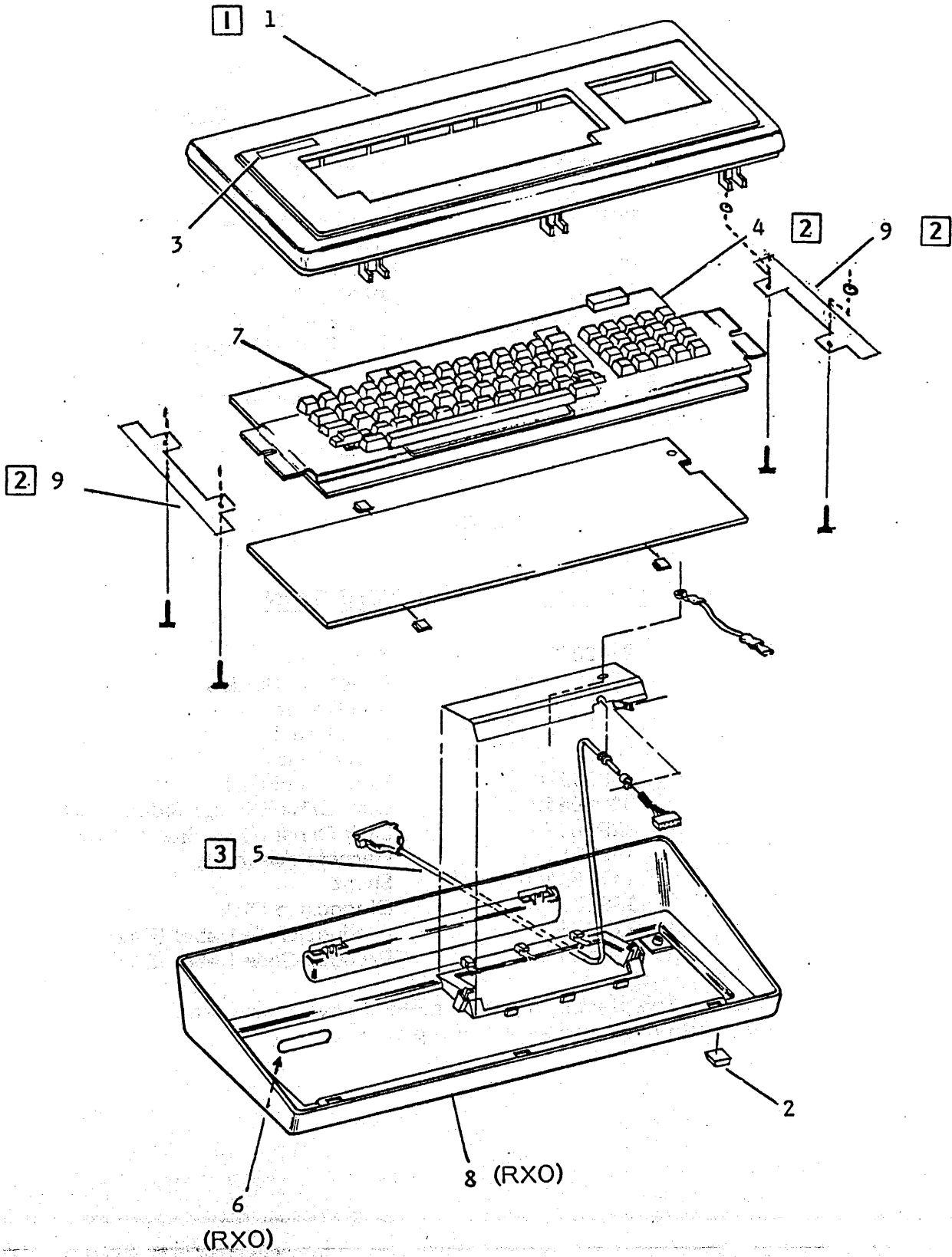

(USO)

<u>ITEM</u>	<u>XEROX PART NO.</u>	<u>DESCRIPTION</u>
1	2S82071 TBA	Top Cover (TSC only) Injection Molded Top Cover (TSC only) See Note 1
2	76S20215	Drive Belt
3	601S868	Head Load Pad
4	82P80650	Disk Drive (Single Sided)
	82P80675	Disk Drive (Dual Sided)
5	152S81236	Harness Assembly
6	601S869	Shunt Kit
7	73S80445	Diagnostic Disk
	73S80504	Dual Sided Diagnostic Disk

NOTE 1 - The plastic injection molded cover has a lead base paint on the inside of the cover.

(RXO)

<u>ITEM</u>	<u>XEROX PART NO.</u>	<u>DESCRIPTION</u>
1	2S82071 TBA	Top Cover Injection Molded Top Cover See Note 1
2	76S20215	Drive Belt
3	76S20216	Head Load Pad
4	82P80650	Disk Drive (Single Sided) (E41)
	82P80675	Disk Drive (Dual Sided) (E44)
5	152S81265	Harness Assembly
6	133P80440	Shunt
7	130S21204	Diagnostic Disk
8	91P81573	Product Code Label (E41)
	91P81608	Product Code Label (E44)

NOTE 1 - The plastic injection molded cover has a lead base paint on the inside of the top cover.

PL 4.3 Disk Drive Assembly (5.25" Single/Dual Sided)

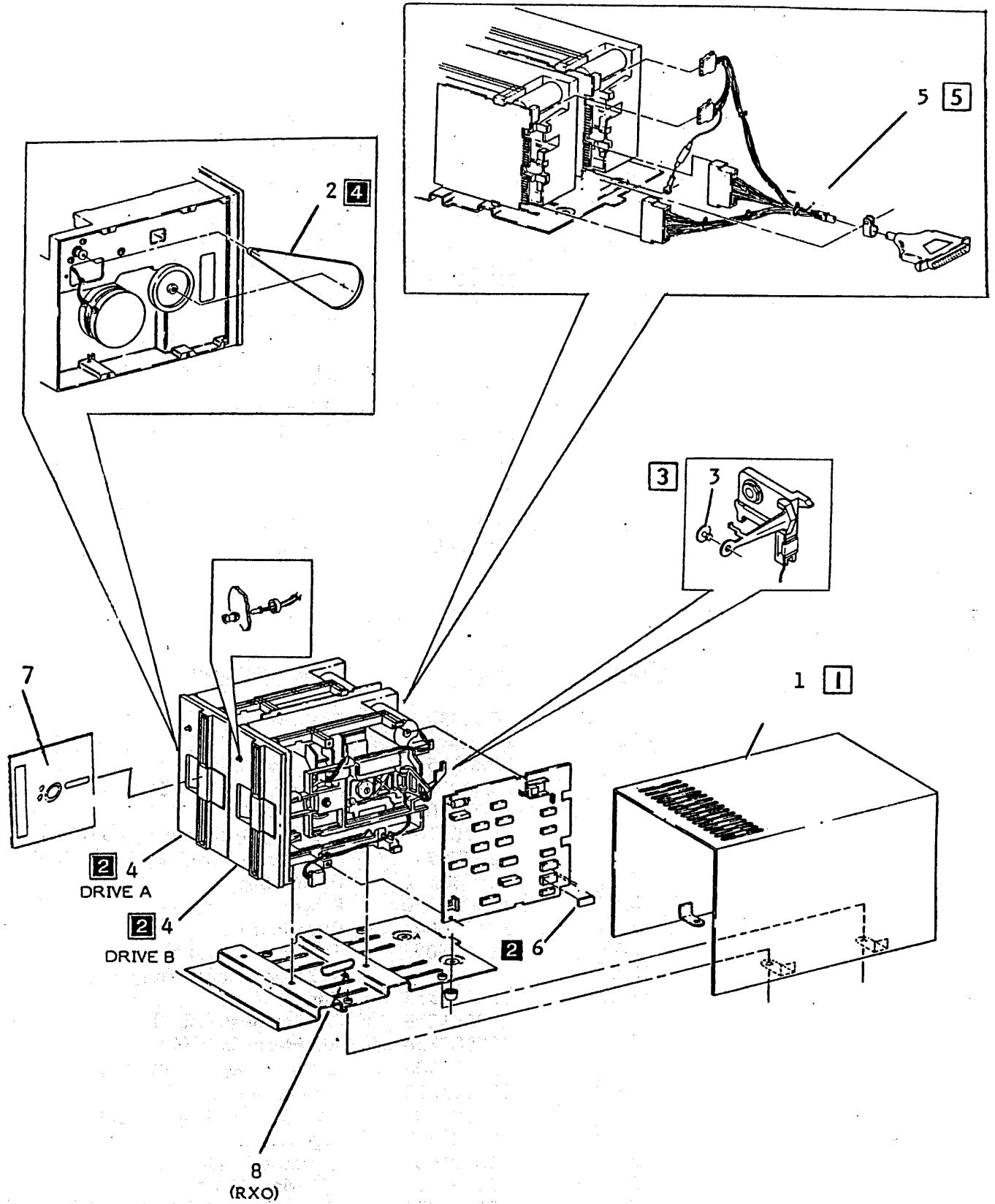

4.0 PARTS IDENTIFICATION

PL 4.4 Disk Drive Assembly (8" Single/Dual Sided)

600P84592

(USO)

<u>ITEM</u>	<u>XEROX PART NO.</u>	<u>DESCRIPTION</u>
1	2P82083	Top Cover (TSC only)
2	601S547	Load Pad (5 per pack)
3	3P80545	Disk Drive Indicator
4	23P80122	Drive Belt (60 HZ)
5	55P80607	Bezel (TSC only)
6	82P80437	Disk Drive (8")SS
	82P80642	Disk Drive (8")DS
7	105P80376	Power Supply
	105P80396	Power Supply (ALT.)
8	110P80470	Power Switch
9	113P1304	Fuse Holder
9A	113P1305	Fuse Holder Cap
10	113S80667	AC Receptacle Assembly
11	127P1290	Fan
12	152S81258	DC Harness
13	152S81259	AC Harness
14	152S81287	Signal Harness
15	73S80446	Diagnostic Disk
	73S80503	Diagnostic Disk (820-II)
16	117P80447	AC Power Cord
17	19P80487	Clamp
19	76S20218	Disk Drive PWA (SS)

A 708W2001 Fuse 5A

XEROX (RXO)

<u>ITEM</u>	<u>XEROX PART NO.</u>	<u>DESCRIPTION</u>
1	2P82083	Top Cover
2	601S547	Load Pad (E42) (5 per pack)
3	3P80545	Disk Drive Indicator
4	23P80121	Drive Belt (50 HZ)
5	55P80607	Bezel (USO)
6	82P80676	Disk Drive Single Sided (E42)
	82P80674	Disk Drive Double Sided (E89)
7	105S80382	Power Supply
8	110P80470	Power Switch
9	113P1304	Fuse Holder
9A	113P1305	Fuse Holder Cap
10		AC Receptacle Assy (USO) (RXO P/O Item)
11	127S80376	Fan
12	152S81258	DC Harness (USO)
13	152S81268	AC Harness (E42)
	152S81308	AC Harness Tag #1 (E42)
	152S81292	Ac Harness (E89)
	152S81307	AC Harness Tag #1 (E89)
14	152S81287	Signal Harness
15	130S21804	Diagnostic Disk
16	152S82370	UK Mains Lead
	152S92371	European VDE Mains Lead
	152S92787	Swiss Mains Lead
17	19P80487	Clamp
18	N/A	Data Label (E42)
	N/A	Data Label (E89)
19	76S80218	Disk Drive PWA
A	708W01601	Fuse 2.0A

600P84592

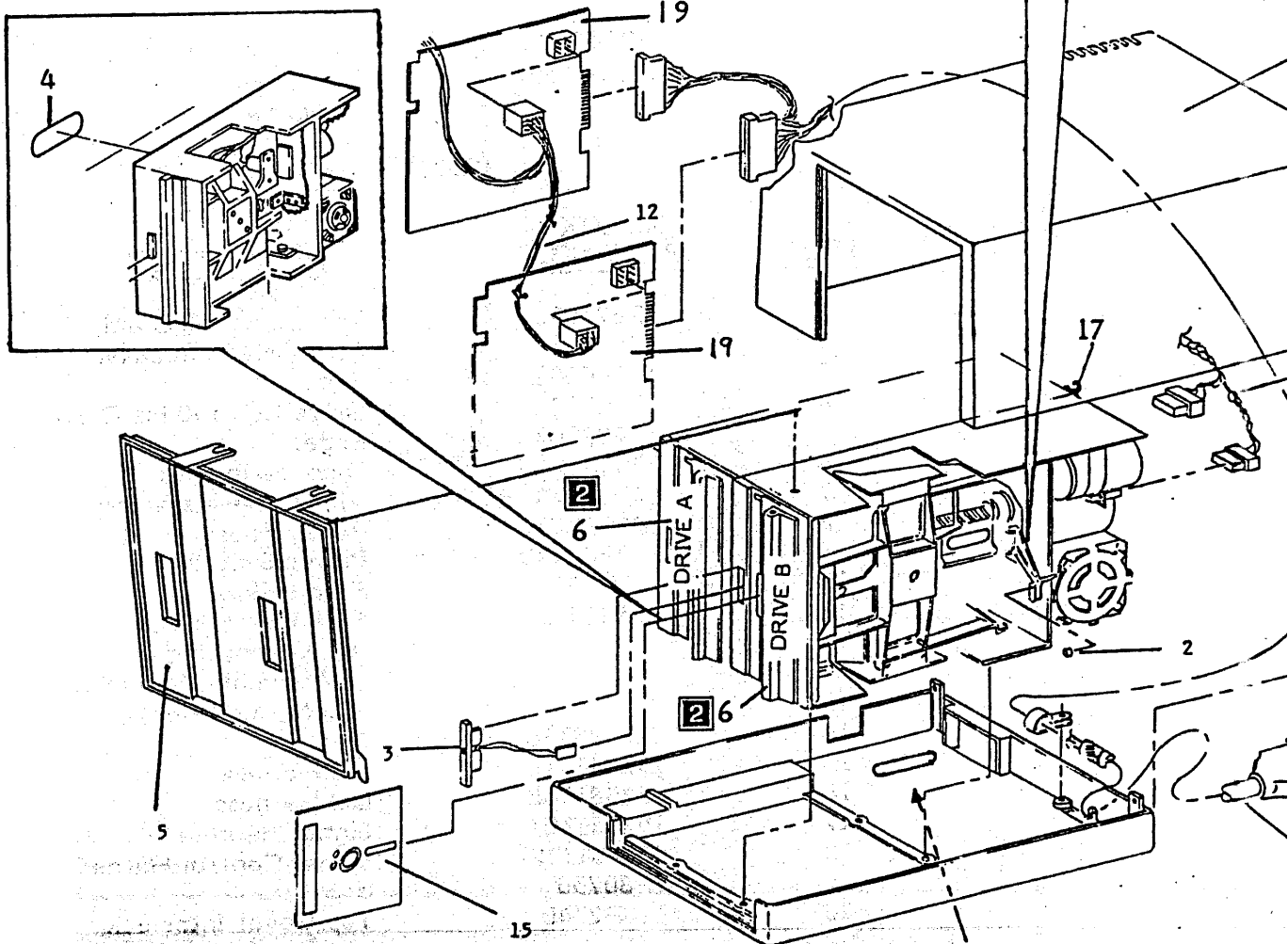
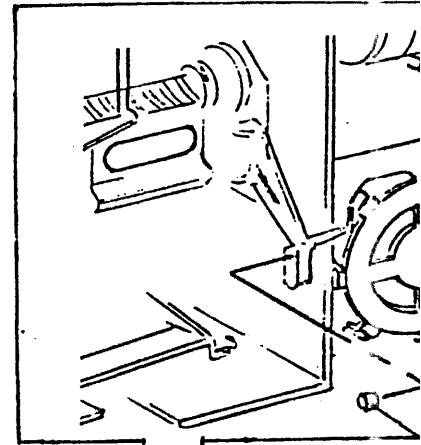
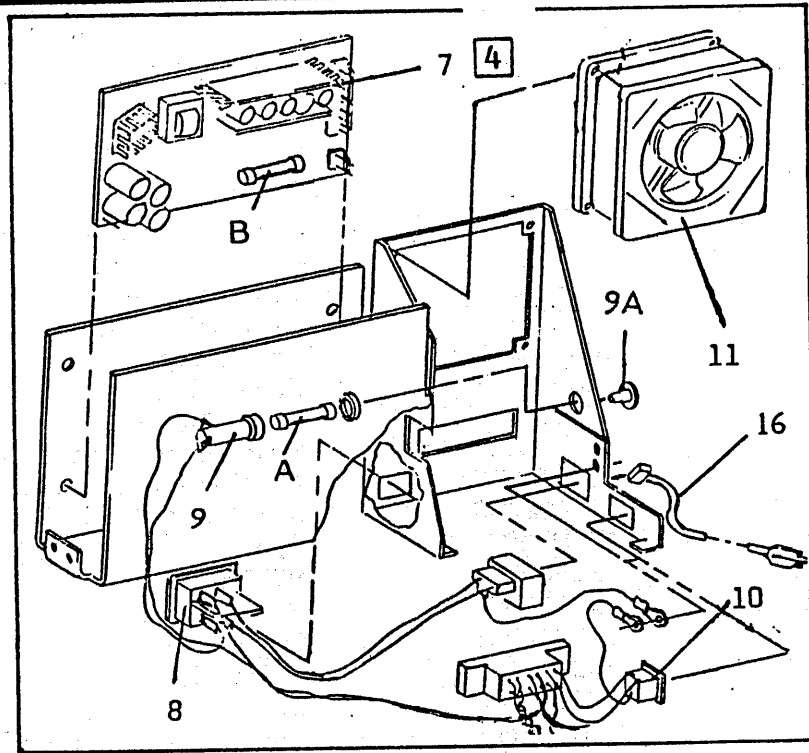

18
RXO

4.0 PARTS IDENTIFICATION

PL 4.5 Disk Drive Assembly (8" Fixed Drive)

600P84592

<u>ITEM</u>	<u>XEROX PART NO.</u>	(USO)	<u>DESCRIPTION</u>
1	2P82107		Top Cover (TSC only)
2	3P80545		Disk Drive Indicator
3	17P80202		Foot
4	23P80122		Drive Belt (60 Hz D.S.)
5	56P80164		Bezel
6	73S80503		Diagnostic Disk
7	82P80642		Disk Drive Assembly 8" D.S.
8	105P80403		Power Supply
9	110P80470		Power Switch
10	113P1304		Fuse Holder
11	113P1305		Fuse Holder Cap
12	113P80667		AC Receptacle Assembly
13	117P80447		AC Power Cord
14	127P1290		Fan
15	152S81301		AC Harness
16	152S81302		DC Harness
17	152S81303		Signal Harness
18	152S81322		Signal Control Harness
19	1P80730		Base (TSC only)
20	110P2340		Top Cover Interlock
A	708W2001		Fuse 5A
B	99P3049		Fuse 2.5A (Package of 5)
C	26P80459		Top Cover Interlock Screw

(RXO)

<u>ITEM</u>	<u>XEROX PART NO.</u>		<u>DESCRIPTION</u>
1	2P82107		Top Cover (TSC only)
2	3P80545		Disk Drive Indicator
3	17P80202		Foot
4	23P80121		Drive Belt (50 Hz D.S.)
5	56P80164		Bezel
6	73S80446		Diagnostic Disk
7	82P80674		Disk Drive Assembly (8"D.S.)
8	105S80409		Power Supply
9	110P80470		Power Switch
10	113P1304		Fuse Holder
11	113P1305		Fuse Holder Cap
12			AC Receptacle Assembly Part of Item 15
13			See PL 4.4 item 16
14	127S80376		Fan
15	152S81310		AC Harness
16	152S81302		DC Harness
17	152S81303		Signal Harness
18	152S81322		Signal Control Harness
19	1P80730		Base
20	110P2340		Top Cover Interlock
A	708W5001		Fuse 4A
B	708W09501		Fuse 1.25A
C	26P80459		Top Cover Interlock Screw

4.0 PARTS IDENTIFICATION

600P84592

PL 4.5 Disk Drive Assembly (8" Fixed Drive)

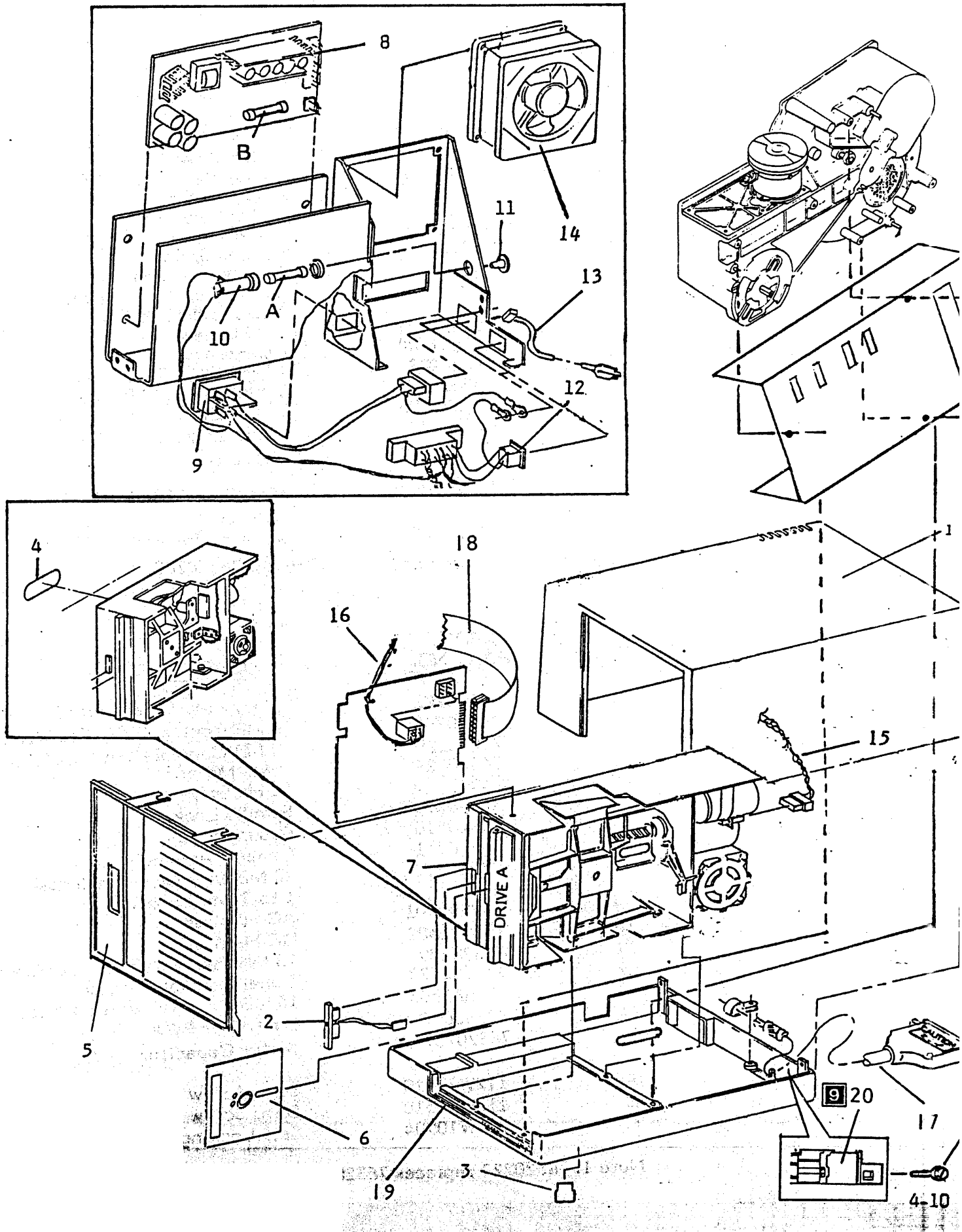

4.0 PARTS IDENTIFICATION

PL4.5 8" Fixed Drive

600P8459

(USO)

<u>ITEM</u>	<u>XEROX PART NO.</u>	<u>DESCRIPTION</u>
1	76S20201	Stepper PWA(See Note 1)
2	76S20202	10 MB Control PWA (See Note 1)
	76S20229	10 MB Control PWA (See Note 1)
3	76S20204	Drive Motor
4	76S20205	60 Hz Drive Belt
5	76S20208	Spindle Lock
6	76S20210	Ground Spring
7	76S20211	Damper Assembly
8	82P80661	10 MB Disk Drive (includes- 1 to 7 and 11 to 13)
9	152S81301	AC Harness
10	152S81302	DC Harness
11	76S20209	10 MB PWA Interconnect Harness
12	152S81322	Signal Control Harness
13	152S81305	10 MB Data Transfer Harness
14	82S80692	Fixed Drive Controller PWA
15	(TSC only)	Capacitor
A	112W24410	Sems Screw (6-32 x 1/4)
B	112W36510	Sems Screw (8-32 x 5/16)
C	220W10904	Self-Locking Nut (8-32)

Note 1: 76S20229 replaces 76S20201 and 76S20202.

(RXO)

<u>ITEM</u>	<u>XEROX PART NO.</u>	<u>DESCRIPTION</u>
1	76S20201	Stepper PWA (See Note 1)
2	76S20202	10 MB Control PWA (See Note 1)
	76S20229	10 MB Control PWA (See Note 1)
3	76S20226	Drive Motor
4	76S20206	50 Hz Drive Belt
5	76S20208	Spindle Lock
6	76S20210	Ground Spring
7	76S20211	Damper Assembly
8	82P80672	10 MB Disk Drive (includes- 1 to 7 and 11 to 13)
9	152S80301	AC Harness
10	152S81302	DC Harness
11	76S20209	10 MB PWA Interconnect Harness
12	152S81322	Signal Control Harness
13	152S81305	10 MB Data Transfer Harness
14	82S80692	Controller PWA
15	76S20227	Motor Capacitor
A	112W24410	Sems Screw (6-32 x 1/4)
B	112W36510	Sems Screw (8-32 x 5/16)
C	220W10904	Self-Locking Nut (8-32)

Note 1: 76S20229 replaces 76S20201 and 76S20202.

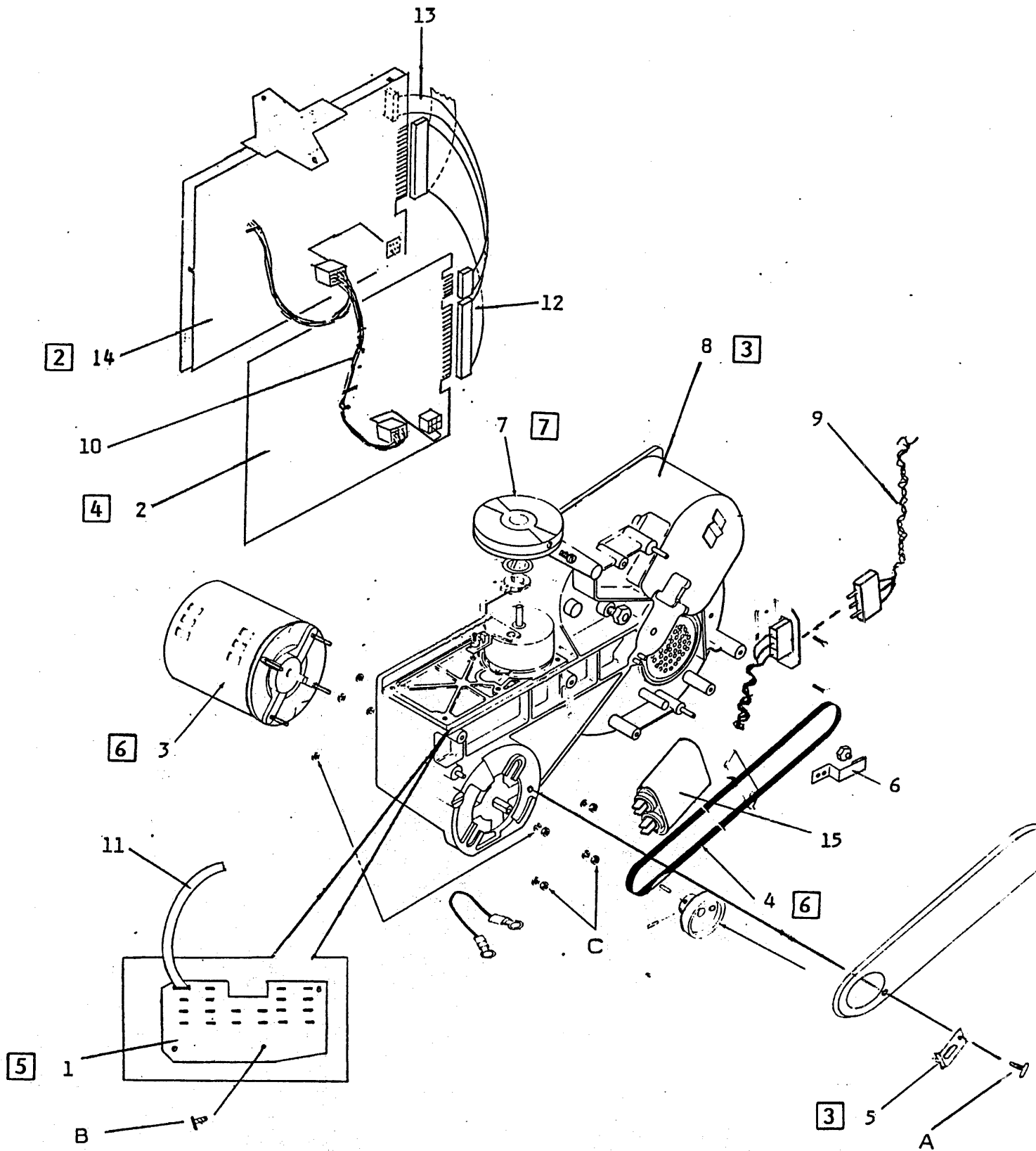

COPY QUALITY

THIS PAGE INTENTIONALLY LEFT BLANK

THIS SECTION DOES NOT APPLY

TROUBLESHOOTING

6.1 INTRODUCTION TO TROUBLESHOOTING

The XEROX 820/820-II is to be serviced using three major fault isolation sequences.

1. Performance of the LEVEL 1 CHECKOUT procedure, which includes visible indications and running Exercisers.
2. Depending on the information obtained in LEVEL 1 CHECKOUT, you will be directed to access one or more of the following:
 - a. Component/Assembly replacement.
 - b. LEVEL 2 CHECKCHART procedures.
 - c. Exercisers.
3. If corrective action does not result in solving the problem, call for assistance from the TSC. (USO)

The Check Charts were written with the knowledge that, if a certain visible indication occurs, several areas are eliminated as possibilities. For this reason, it is absolutely necessary that the LEVEL 1 CHECKOUT procedure be followed in the sequence given and that no exceptions be made. For example, if you miss a visible indication and later an error occurs, the CHECKCHARTS will have assumed you saw the visible and it was correct, therefore some areas which could cause the error will not be checked. The results will be the check charts will not be effective. If an error does not occur, the performance of the Level 1 Checkout will have eliminated most of the possibilities and the remaining possibilities can be checked quickly.

If you have spent a reasonable amount of time (determined by local management) and do not see an immediate correction to the problem, you should request assistance from the TSC. The TSC is your support in solving the problem. (USO)

6.2 LEVEL 1 CHECKOUT EXPLANATION

Figure 6-1 shows a sample of the LEVEL 1 CHECKOUT procedure. Notice the three columns.

1. Procedure - This column details the action(s) required to perform the step.
2. Visible Indications - Indications in this column identify visible indicators of properly operating system. Each of these visuals must be checked and verified in the sequence given. If the sequence is not followed, the LEVEL 2 access cannot be depended upon to properly isolate the faulty component.
3. Level 2 Access - This column identifies the corrective action to take if one of the visible indications do NOT occur, is incorrect, or if a Fault Code is reported, a number in this column identifies the LEVEL 2 CHECK CHART procedure to use. In some cases, you may either be directed to see the replace a part or you may be directed to continue to the next visible listed in the Level 1 Check Chart. In other cases, you may be directed to "See NOTE." The NOTE will be found following the statement.

All notes within the LEVEL 1 must be followed. They tell you what to do during or after the LEVEL 1 is performed.

A visible indication of the LEVEL 1 will reference you to one or more of the following:

- a. LEVEL 2 CHECK CHART procedures.
- b. Component Replacement.

STEP PROCEDURES	VISUAL INDICATORS	LEVEL 2 ACCESS
<p>① 1. Check for obvious problem. Repair if solution is apparent (refer to repair procedures.)</p> <p>2. Remove any floppy discs from drives.</p> <p>3. Turn system OFF.</p> <p>4. Wait 10 seconds then turn system ON.</p> <p>5. Insert diagnostic disc in the left hand disc drive.</p> <p>6. Type A on the keyboard.</p>	<p>②</p> <p>After 10 seconds ...XEROX is displayed.</p> <p>A displayed on the screen</p>	<p>③</p> <p>Procedure 1.0</p> <p>Keyboard Processor PWB Keyboard Harness</p>

Figure 6-1 Sample LEVEL 1 CHECKOUT

6.0 TROUBLESHOOTING

6.3 Level 2 Checkout Explanation

600P84592

6.3 LEVEL 2 CHECK CHART EXPLANATION

Figure 6-2 is a sample of a LEVEL 2 CHECK CHART. Notice the different column headings.

1. Within this box is the number and name of the Level 2 procedure.
2. Step - This column lists the number for each step of the procedure. Not all steps will be performed. Only perform those steps necessary to isolate the faulty component(s).
3. Procedure - This column describes the set-up required, if any. If it is a voltage, the tolerance is given.

All AC voltages will be written as VAC, and all DC voltages will be written as VDC. Always turn the system power off when disconnecting/connecting plugs or removing/inserting PWA's. DC voltage are to be assumed positive unless a minus (-) is shown prior to the voltages.

4. Test Point - The column identifies how or where to check the procedure statement. If a voltage reading is to be made, the first entry is for the RED or (+) lead and the second entry is for the BLACK or (-) lead. If no second entry exists, the BLACK lead must be connected to any good machine frame ground (not on painted or non-metallic surfaces). Chapter 4, (PARTS LIST) or Chapter 7, (PLUG/JACK LIST) can be used to locate the component or plug/jack where the test is to be made.
5. Correct Indication - If the voltage or visual observed was CORRECT or occurred as stated in the procedure; this column will either direct you to the next place to continue troubleshooting or it will direct you to replace a component or perform an adjustment.
6. Incorrect Indication - If the voltage or visual observed was INCORRECT or did NOT occur as stated in the procedure; this column will either direct you to the next place to continue troubleshooting or it will direct you to replace a component or perform an adjustment. These steps must be followed as listed.

6.5 Level 2 Check Chart Procedures		600P83800		
STEP	PROCEDURE	TEST POINT	INDICATION	
			CORRECT	INCORRECT
1.	Measure voltage at input of Power Supply, voltage should be within 90 and 130 VAC. (USO) 190-242VAC or 215-264VAC (RXO)	P1 1-3	Step 2	Check wiring and S-1 between power cord and power supply.
2.	Measure voltage at output of Power Supply, voltage should be within 4.25 and 5.25 VDC	P5 - 4 (-) P5 - 8 (+)	Step 3	Power Supply
3.	Measure Voltage at output of Power Supply, voltage should be 12 VDC	P5 - 4 (-) P5 - 2 (+)	Step 4	Power Supply
4.	Check Brightness Control Potentiometers. When moving Potentiometer, Voltage should go between 0VDC and 150 VDC	P1 - 3 (-) P1 - 2 (+)	Step 5	Monitor Brightness Control

Figure 6-2 Sample LEVEL 2 CHECK CHARTS

STEP PROCEDURES	VISUAL INDICATORS	LEVEL 2 ACCESS
<ol style="list-style-type: none"> 1. Check for obvious problem. Repair if solution is apparent (refer to repair procedures.) 2. Remove any floppy discs from drives. 3. Turn system OFF. 4. Wait 10 seconds then turn system on. 	<p>NOTE: Display for 820 Systems ...XEROX 820 VER.X.X... A-BOOT SYSTEM T-TYPEWRITER</p>	Procedure 1.0
<p>After 10 seconds</p>	<p>NOTE: Display for 820 II System 820-II VER. XX 1982 XEROX CORP. L - LOAD SYSTEM H - HOST TERMINAL T - TYPEWRITER</p>	Procedure 1.0
<ol style="list-style-type: none"> 5. Insert diagnostic disc in the left disc drive. 6. NOTE: This step does not apply to the Fixed Drive. Insert initialized disc in right disc drive. 		
<ol style="list-style-type: none"> 7. Type A for 820 Type L A for 820-II 	<p>A displayed on the screen L A displayed on the screen</p>	<p>Keyboard Daughter PWA (820 II Only) Processor PWA Keyboard Harness</p>
<ol style="list-style-type: none"> 8. NOTE: Do not press any key(s) while diagnostics are running, after pressing the return key, unless instructed to do so Press the RETURN key 	<p>NOTE: Display for 820 Systems COPYRIGHT (C) 1981, XEROX CORP. CP/M REG. TM X.X DI X.X (Serial No.)</p> <p>NOTE: Display for 820 II System 820-II XEROX 60K CP/M VER. XX XXX.</p>	<p>Procedure 2.0 (Procedure 6.0 for Fixed Drive System)</p>
<p>NOTE: During the remainder of Level 1, if at any time a disc error is displayed, perform Procedure 3.0. This note does not apply to the QDISK Procedures.</p>	Error Message Displayed	Procedure 3.0
<ol style="list-style-type: none"> 9. Observe the visual indicators while the following tests are running and respond accordingly. 		
<ul style="list-style-type: none"> o MTEST 0001 	<p>MAP OF TESTED MEMORY Passes complete = 0001; Count of Error Bytes = 0000</p>	Processor PWA
<ul style="list-style-type: none"> o MTEST2 	<p>MAP OF TESTED MEMORY Passes complete = 0001 Count of Error Bytes = 0000</p>	Processor PWA

The data in this column will remain the same for all systems.

The data in these columns will vary from system to system but the format will remain the same.

1000	78	C3	F3	0D	E1	F1	CA	28	0E	23	22	B9	0F	EB	21	A8	x.....(.#"....!
1010	06	4E	23	46	CD	57	08	DA	28	0E	CD	C8	0D	2A	4A	0F	.N#F.W..(.....*J.
1020	EB	3E	82	B7	37	C3	85	08	FB	2A	4D	0F	7C	B5	CA	4E	.>..7.....*M. ...N
1030	0E	2B	22	4D	0F	CD	1F	0C	C2	4E	0E	3A	4C	0F	B7	C2	."M.....N.:l...
1040	48	0E	CD	85	0E	C3	85	08	CD	44	0D	C3	85	08	CD	C8	H.....D.....
1050	0D	3E	2A	CD	C7	0B	2A	B9	0F	CD	93	09	D2	62	0E	22	.>*...*.....b."
1060	0C	00	CD	2E	0C	2A	B7	0F	22	5D	0F	C3	FE	06	11	0D*..."].....
1070	00	21	2F	0F	7E	A0	23	BE	23	CA	81	0E	14	1D	C2	74	./!/.~.#.#.....t
1080	0E	5A	16	00	C9	2A	B9	0F	46	23	E5	CD	6E	0E	21	49	.Z...*..F#..n.!I
1090	0F	73	21	9C	0E	19	19	5E	23	56	EB	E9	B8	0E	E0	0E	.s!.....^#V.....
10A0	B8	0E	E0	0E	BE	0E	F2	0E	04	0F	26	0F	26	0F	23	0F&&.#.
10B0	23	0F	19	0F	26	0F	14	0F	CD	CE	0E	C2	29	0F	CD	D9	#...&.....)...
10C0	0E	C3	29	0F	3A	A8	06	BB	C0	3A	A9	06	BA	C9	C1	E1	..):.....:.....
10D0	5E	23	56	23	E5	C5	C3	C4	0E	2A	B5	0F	5E	23	56	C9	^#V#.....*..^#V.
10E0	CD	CE	0E	CA	ED	0E	C1	C5	3E	02	C3	2B	0F	D1	D5	C3>..+.....
10F0	29	0F	78	FE	FF	C2	FC	0E	AF	C3	2D	0F	E6	38	5F	16).x.....-...8_.

Figure 1-1 Disc Data Log

STEP PROCEDURES	VISUAL INDICATORS	LEVEL 2 ACCESS
<ul style="list-style-type: none"> o GDISK <ul style="list-style-type: none"> Disk test Read/Write test Random seek test Read Write test 	<ul style="list-style-type: none"> 0 Read/Write errors detected 0 Seek errors detected 	Procedure 7.0
<p>NOTE: On 5.25" disc drives only if an initialized disc was not inserted in drive B, a bios and drive not ready will be displayed. To continue test, press the CTRL key and type CC. The screen will display a Bdos Err On B: Select will be displayed.</p>		
<p>NOTE: If printer is not ON/CONNECTED, test will stop, after this step.</p>		
<ul style="list-style-type: none"> o TERM <ul style="list-style-type: none"> Diagnostics II V1.1 Terminal test 	Test patterns look normal on the screen	Procedure 4.0
<ul style="list-style-type: none"> o PRINTER TEST <ul style="list-style-type: none"> Diagnostics II - Printer Exerciser. v1.6 (630 only) 	<ul style="list-style-type: none"> Printer test pattern is normal. Printer inoperative. 	<ul style="list-style-type: none"> Printer Service Manual Step 11

DOUBLE SIDE DISK TEST

5.25" DISC DRIVE

10. Reset machine when printer test is complete and leave diagnostic disc in drive A.

A. Enter in the following from the keyboard:

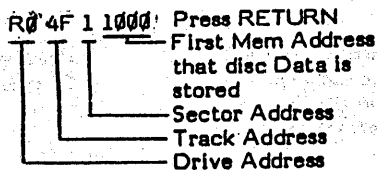

Memory address 1000-10F0 containing disc DATA will be displayed on the screen in the same format as Figure 1.

Left Drive

B. **NOTE:** This test drive B of A Double sided disc only.

Enter in the following from the keyboard
R1 4F 1 1000

Memory Address 1000-10F0 containing disc data will be displayed on the screen in the same format as Figure 1.

Right Drive

STEP PROCEDURES	VISUAL INDICATORS	LEVEL 2 ACCESS
8" DISC DRIVE		
Reset machine when printer test is complete and leave diagnostic disc in drive A.		
A. NOTE: This will test the second side of a double sided disc. N/A to single side disc		
Enter in the following from the Keyboard R0 4D 1 1000	Memory Address 1000-10F0 containing disc data will be displayed on the screen in the same format as Figure 1.	Left Drive
B. NOTE: This test drive B. of A double sided disc only.		
Enter in the following from the keyboard R1 4D 1 1000	Memory Address 1000-10F0 containing disc will be displayed on the screen in the same format as Figure 1.	Right Drive
FIXED DRIVE ASSEMBLY		
Reset machine when printer test is complete and leave diagnostic disc in drive A.		
A. NOTE: This test the second side of drive A.		
Enter in the following from the keyboard R0 4D 1 1000	Memory Address 1000-10F0 containing disc data will be displayed on the screen in the same format as Figure 1.	Left Drive
B. Enter the following from the keyboard R4 1 1F 1000		
R4 1 3F 1000	Same as Step B.	Procedure 7 Step 2.
R4 1 5F 1000	Same as Step B.	Procedure 7 Step 2.
R4 1 7F 1000	Same as Step B.	Procedure 7 Step 2.

600P84592

6.4 Level 1 Checkout Procedures

STEP PROCEDURES	VISUAL INDICATORS	LEVEL 2 ACCESS
11. PRINTER LOOPBACK TEST		
Turn system power off.		
Install loopback tool on Processor printer connector.		
Turn system power on.		
ENTER <u>005 D5</u> press RETURN.		
ENTER <u>105</u> press RETURN.	05 D5	Processor PWA
Press space bar.		
ENTER <u>005 2A</u> press RETURN.		
ENTER <u>105</u> press RETURN.	05 2A	Processor PWA
Press space bar.		
ENTER <u>00C 07</u> press RETURN.		
ENTER <u>005 D5</u> press RETURN.		
ENTER <u>105</u> press RETURN.	05 D5	Processor PWA
Press space bar.		
ENTER <u>005 2A</u> press RETURN.		
ENTER <u>105</u> press RETURN.	05 2A	Processor PWA
If Printer Loopback Test is good, high probability 820 Processor is not at fault. Use your P1/1730 Service Manual to repair Printer.		
12. COMM. LOOPBACK TEST		
Turn system power off.		
Install loopback tool on Processor Comm. connector.		
Turn system power on.		
ENTER <u>006 04</u> press RETURN.		
ENTER <u>006 45</u> press RETURN.		
ENTER <u>006 01</u> press RETURN.		
ENTER <u>006 00</u> press RETURN.		
ENTER <u>006 03</u> press RETURN.		
ENTER <u>006 41</u> press RETURN.		
ENTER <u>006 05</u> press RETURN.		
ENTER <u>006 2A</u> press RETURN.		
ENTER <u>000 05</u> press RETURN.		
ENTER <u>004 D5</u> press RETURN.		
ENTER <u>104</u> press RETURN.	04 D5	Processor PWA
Press space bar.		

cont.

STEP PROCEDURES	VISUAL INDICATORS	LEVEL 2 ACCESS
ENTER 004 2A press RETURN.		
ENTER 104 press RETURN.	04 2A	Processor PWA
Press space bar.		
ENTER 000 07 press RETURN.		
ENTER 004 D5 press RETURN.		
ENTER 104 press RETURN.	04 D5	Processor PWA
Press space bar.		
ENTER 004 2A press RETURN.		
ENTER 104 press RETURN.	04 2A	Processor PWA

If Comm. Loopback Test is good, high probability 820 Processor is not at fault.

600P84592

6.5 Level 2 Check Chart Procedures

STEP	PROCEDURE	TEST POINT	INDICATION	
			CORRECT	INCORRECT
1.0 ... XEROX IS NOT DISPLAYED				
1.	Measure voltage at input of Power Supply, Voltage should be within <u>90 and 130 VAC</u>	P1 1-3	Step 2	Verify AC Source Voltage Check wiring and S-1 between power cord and power supply. NOTE: If processor is plugged into Drive Box check Interlock Switch on Fixed Drive and fuse F-1 on rear of box.
2.	Measure voltage at output of Power Supply, voltage should be within <u>4.75 and 5.25 VDC</u>	P5 - 8 P5 - 4	Step 3	
3.	Measure Voltage at output of Power Supply, voltage should be <u>12 VDC.</u>	P5 - 2 P5 - 4	Step 4	Power Supply
4.	Check Brightness Control Potentiometer: PWA When moving Potentiometer, Voltage should go between <u>OVDC and 150 VDC</u>	P1 - 2 P1 - 3 (Brightness Control PWA)	Step 5	Monitor PWA Brightness Control
5.	Measure video output voltage should be <u>.1 VDC to .4VDC</u>	J1 - 8 J1 - 1 (Monitor PWA)	Step 6	Verify shunt configuration figure 3.8 Processor PWA
6.	Measure horizontal sync, voltage should be <u>1.8 VDC to 3.0 VDC</u>	J1 - 6 J1 - 1 (Monitor PWA)	Step 7	Processor PWA
7.	Measure vertical sync, voltage should be <u>3.8 VDC to 5.2 VDC</u>	J1 - 9 J1 - 1	Step 8	Processor PWA
8.	Increase brightness control on monitor PWA until raster is visible.	Raster visible?	Daughter PWA Processor PWA	Monitor
2.0 COPYRIGHT (C) 1981, XEROX CORP.XEROX NOT DISPLAYED				

- Depress Reset Switch.
- Insert Diagnostic Disc in right drive.
- Type B and press RETURN
NOTE: On 820-II, type LB and return.

COPYRIGHT (C) 1981, XEROX CORPORATION

CP/M REG. TM X.X DI X.X (Serial No.)

bios select error drive not ready

Visual

Clean Heads on Left Disc Drive
Check motor speed 3.3.4 5.25" only (Left disc load pad single side drives only)
Left disc drive

Verify Diagnostic Disk

Procedure 5

6.0 TROUBLESHOOTING
6.5 Level 2 Check Chart

600P84592

STEP	PROCEDURE	TEST POINT	INDICATION	
			CORRECT	INCORRECT
3.0 ERROR IS DISPLAYED				
NOTE: Clean drive heads repeat Level 1 checkout.				
5.25" Disc Drive				
1.	Reconfigure (strap) the left drive for physical drive B, and the right drive for physical drive A by swapping the shunts and installing the resistor network on the left drive.		Verify Diskette Check motor speed 3.3.4 Load Pad (Single side only) Left disc drive	Processor PWA Daughter PWA Signal Harness (820-II only)
2.	Repeat Level 1 checkout thru Step 9 with the Diagnostic Disc in the right disk drive.			
8" Floppy Drive				
1.	Move DS1 Jumper to DS2 on drive "A". Move DS2 Jumper to DS1 on drive "B".		Verify diskette Load pad (single side only) Left disc drive	Daughter PWA (820 II only) Processor PWA Signal Harness
	Repeat Level 1 checkout thru Step 9 with the Diagnostic Disc in the right disk drive.			Daughter PWA (820-II only) Processor PWA Signal Harness
FIXED DISC ASSEMBLY				
1.	Reset machine and enter in the following from the keyboard: R4 0 0 1000 press RETURN	Memory Address 1000-10F0 containing disc data will be displayed on the screen in the same format as Figure 1.	Verify Diskette Left Drive Signal Control Harness	Daughter PWA (820-II only) Processor PWA Fixed Controller PWA Signal Harness
4.0 TEST PATTERNS NOT CORRECTLY DISPLAYED				
1.	Entire Screen is distorted.	Visual	Adjust mon- iter PWA 3.1.2	Processor PWA
5.0 COPYRIGHT (C) 1981, XEROX CORP. NOT DISPLAYED				
5.25" DISK DRIVE				
1.	Measure voltage at input of Disc Drive, voltage(s) should be:			

STEP	PROCEDURE	TEST POINT	INDICATION	
			CORRECT	INCORRECT
a)	12VDC	P/J2-1 P/J2-2	step b	Check wiring between Processor PWA and drive.
b)	4.75 to 5.25VDC	P/J2-4 P/J2-3	Step 2	Check wiring between Processor PWA and drive.
2.	Power down, then disconnect signal harness from Disc Drive (B). Power up and insert Diagnostic Disc in disc Drive (A), type A and press RETURN.	COPYRIGHT displayed MTEST RUNS	Disc Drive(B) Signal Har- ness.	Step 3
3.	Power down, and reconnect drive (B), disconnect signal harness from Disc Drive (A). Power up and insert diagnostic disk in Disc drive (B), type B and press RETURN. NOTE: If 820-II system, type LB and press return.	COPYRIGHT BIOS select ERROR drive not ready displayed.	Disc Drive (A) Signal Har- ness	Daughter PWA (820-II only) Processor PWA Signal Harness

8" DISK DRIVE

1.	Measure input voltages at disk drive (3.4.4) figure 3-24 .		step 2	Check Fuse drive power supply
2.	Power down, and disconnect signal harness from Disk Drive (B). Power up and insert diagnostic disc in drive (A), type A and press return.	COPYRIGHT displayed	Disk Drive(B) Signal Harness	step 3
3.	Power down and remove T3, T4, T5, T6 from disk Drive (A), install them on Disk Drive (B). Reconnect Disk Drive (B), disconnect signal harness from Disk Drive (A). Power up insert diagnostic disc in disk drive (B), type B and press return. NOTE: If 820-II system, type LB and press return.	COPYRIGHT BIOS select ERROR drive not ready displayed.	Head load pad Disk Drive (A) Signal Har- ness	Daughter PWA (820-II only) Processor PWA Signal Har- ness

6.0 XEROX CP/M 60K VXX NOT DISPLAYED

1.	Verify interlock engage. Refer to Procedure 3.5.9.			
2.	NOTE: This manually reads data from the fixed drive. Depress reset switch and type in: R4 0 0 1000 press RETURN	Memory Address 1000-10F0 containing disc data will be displayed on the screen in the same format as Figure 1.	Clean Left disc heads Verify diagnostic disc Left disc Drive	Step 3

STEP	PROCEDURE	TEST POINT	INDICATION	
			CORRECT	INCORRECT
3.	Power off and disconnect power cord. Remove top cover (procedure 3.5.1) Disconnect P1 from 10 meg Byte board. Reconnect power cord, engage top cover interlock and power on. Insert diagnostic disc in left drive. Type LA and press RETURN.	Xerox CP/M 60K VER. XX Displayed	10MB Control PWA	Step 4
4.	NOTE: This manually reads the fixed disc. Remove disc from left drive Power off and unplug power cord. Reconnect PJ-1 on 10 Meg Byte control PWA. Disconnect PJ-1 on 8" drive. Reconnect power cord and power on. Reset machine and type in: R4 0 0 1000	Memory Address 1000-10F0 containing disc data will be displayed on the screen in the same format as Figure 1.	Left disc Drive	Power System down. Reconnect PJ-1 to left drive and proceed to step 5.
5.	Measure voltage at output of the disc drive power supply connector PJ-3, voltage should be -5VDC \pm .25 vdc.	J3-1 J3-6	Step 6	Check fuse F1 Drive power supply
6.	Measure voltage A1 output of the disc drive power supply connector PJ-3, voltage should be +5VDC \pm .25vdc.	J3-8 J3-4	Step 7	Check fuse F1 Drive power supply
7.	Measure voltage at output of the disc drive power supply connector PJ-3, voltage should be +24vdc \pm 1.2 vdc	J3-2 J3-5	Step 8	Check fuse F1 Drive power supply
8.	Measure voltage at output of the disc drive power supply connector PJ-3, voltage should be + 5vdc \pm .25 vdc.	J3-9 J3-4	Step 9	Check fuse F1 Drive power supply
9.	Measure voltage at output of the disc drive power supply connector PJ-3, voltage should be + 24 vdc \pm 1.2 vdc	J3-3 J3-5	Step 10	Check fuse F1 Drive power supply
10.	Measure voltage at output of the disc drive power supply connector PJ-3, voltage should be - 5 vdc \pm .25 vdc	J3-7 J3-6	Daughter PWA Processor PWA Fixed Drive PWA Signal Harness	Check fuse F1 Drive power supply

7.0 Q DISC ERRORS

5.25" AND 8"			
1.	If error verify floppy diskette is good and repeat level 1 check out	Error displayed on screen	Step 2
2.	Clean heads and repeat level 1 checkout	Error displayed on screen	Step 3

6.5 Level 2 Check Chart Procedures

STEP	PROCEDURE	TEST POINT	INDICATION	
			CORRECT	INCORRECT
3.	Errors displayed when checking drive A only. Repeat level 1 to checkout the drive after doing each step under the correct column.	Drive A disc error displayed on screen	Check motor speed (5.35") Load pad on single side drives. Replace drive A Daughter PWA (820-II system) Processor PWA Signal Harness	Step 4
4.	Errors displayed when checking Drive B only. Repeat level 1 to checkout the drive after doing each step under the correct column.	Drive B disc displayed on screen	Check motor speed (5.25" only) Load pad on single side drives Replace Drive B Daughter PWA (820-II system) Processor PWA Signal Harness	Step 5
5.	Errors when checking drives A and B. Repeat level 1 checkout after doing each step.	Error displayed on screen	Daughter PWA Processor PWA Signal Harness	
FIXED DRIVE ASSEMBLY				
1.	Verify floppy diskette in drive A. Repeat level 1 checkout	errors displayed		Step 2
2.	Errors indicate problem on drive A.	Errors displayed on screen	Drive A	Step 3
3.	Errors indicate problem on drive B.	Errors displayed on screen	Step 4	Repeat Level 1 checkout
4.	Remove top cover, engage top cover interlock switch and power up the disc drive.	Disc drive motor is rotating and belt is in place.	Step 7	Motor not turning, Go to step 5 Belt off pulley Go to step 6

6.5 Level 2 Check Chart Procedures

STEP	PROCEDURE	TEST POINT	INDICATION	
			CORRECT	INCORRECT
5.	Check AC input to motor, voltage should be 115 vac	P/J-4 Pins 1 to 3	Check for Bind. Replace motor	Identify why voltage is not present at motor
6.	Disc drive belt off pulley	Visual	Replace drive belt if worn or broke (3.5.6)	
7.	Check damper for oil leads	leaking oil	Replace damper (3.5.7)	10MB PWA Stepper PWA Fixed controller PWA Disc signal Harness Step 8

CAUTION

The following procedure can erase all customer files. Verify the customer has backup files on floppy disc so they can re-enter the data erased.

8.	Check the integrity of the fixed disc media by running the following backup procedure:			
A.	Insert CP/M disc in left drive		Step B	Repeat Step A
B.	Press reset	820-II VER.XXX 1982 Xerox Corp. L-Load System H-Host Terminal T-Typewriter		Repeat step B
C.	Enter L A on the keyboard	820-II Xerox 60K CP/M VER.XXXXX	Step D	Repeat step A & B
D.	Enter BACKUP on the keyboard and press RETURN	Backup menu will be displayed on screen	Step E	Repeat step D
E.	Enter 4 on the keyboard to verify disc integrity	Screen will display: Verify which disc	Step F	Repeat step E
F.	Enter E on the keyboard	Program will begin to run with increment block counts displayed on screen, on which bad blocks may appear.	If block count is completed or bad block appears go to step 6.	Step 9

6.5 Level 2 Check Chart Procedures

STEP	PROCEDURE	TEST POINT	INDICATION	
			CORRECT	INCORRECT
G.	If program shows any bad blocks they should be accepted by (typing A) so program will continue. If no bad blocks appear program will complete. Then press Return	All done Touch any key to exit	Step H	Step 9
H.	Touch return again	Back up menu will be displayed on screen	Step I	Verify CP/M disc
I.	Repeat steps A through H substituting (F) for drive to be verified	Same as A thru H	Step J	Step 9
J.	Repeat steps A through H substituting (G) for drive to be verified	Same as A thru H	Step K	Step 9
K.	Repeat steps A through H substituting (H) for drive to be verified	Same as A thru H	Step L	Step 9
L.	Return system to customer after call management. Inform the customer that the system will no longer allow them to access the bad media. Now go to step			
9.	Format fixed disc media by performing the following procedures:			
A.	Reset system		Step B	Repeat step A
B.	Insert CP/M disc in drive A		Step C	Repeat step A thru B
C.	Enter L A on keyboard and press RETURN		Step D	Repeat step A thru C
D.	Enter FMT on keyboard and press RETURN	Initializing will erase all the data on the fixed disc touch (any key) to exit or (return) to continue	Step E	Repeat steps A thru D
E.	Press RETURN on the keyboard to continue	Are you sure you want to continue	Step F	Repeat steps A thru E
F.	Press Y on the keyboard to continue	Tracks being initialized will be displayed on the screen and will count up to 1023	Press reset and repeat step 8	10 MB disc drive

6.0 TROUBLESHOOTING

6.6 Chain 1.1 AC/DC Distribution

600P84592

SYSTEM WITH 5.25" DISC DRIVE ASSEMBLY

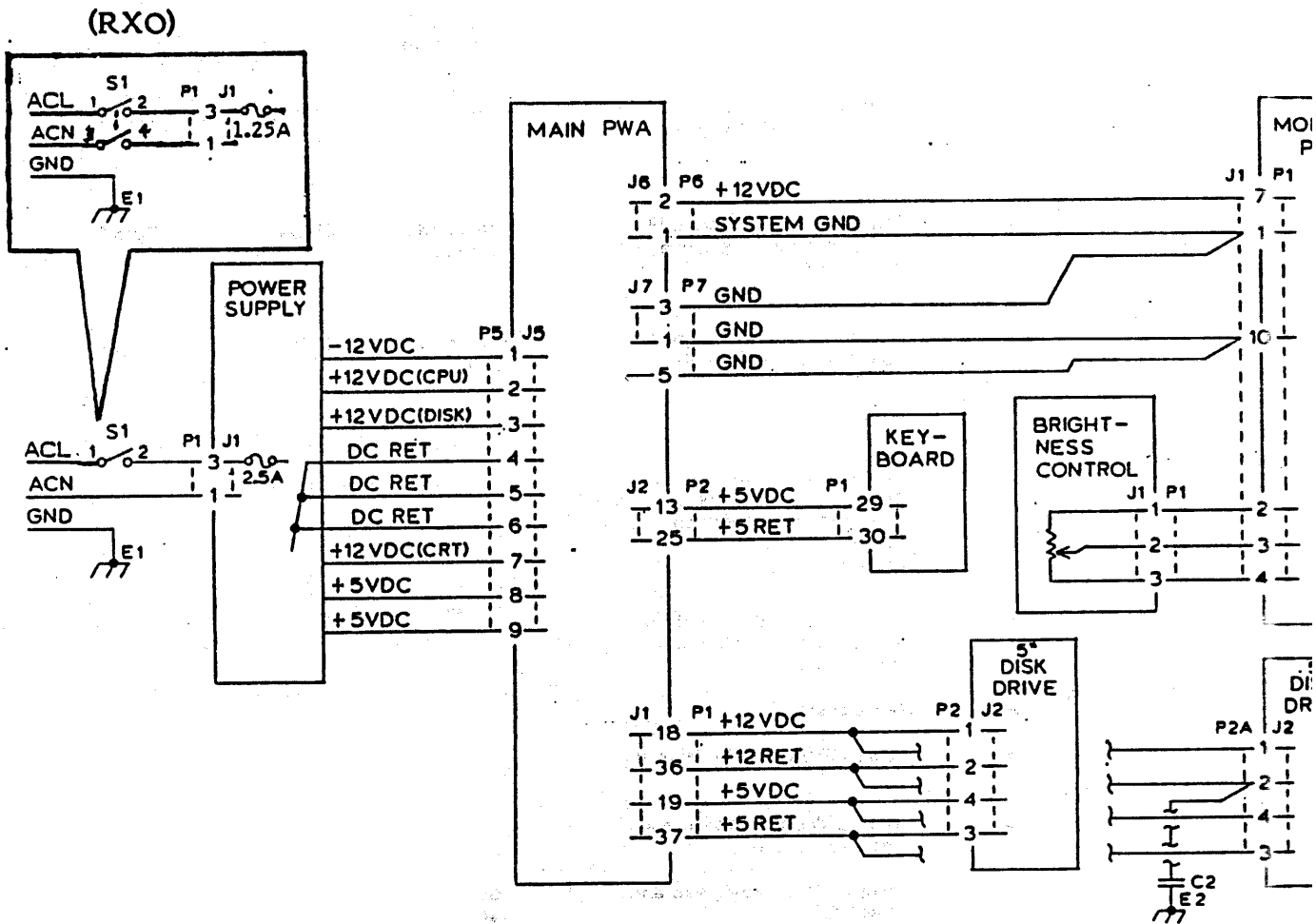

- AC/DC DISTRIBUTION

600P84592

8" DISC DRIVE ASSEMBLY (US)

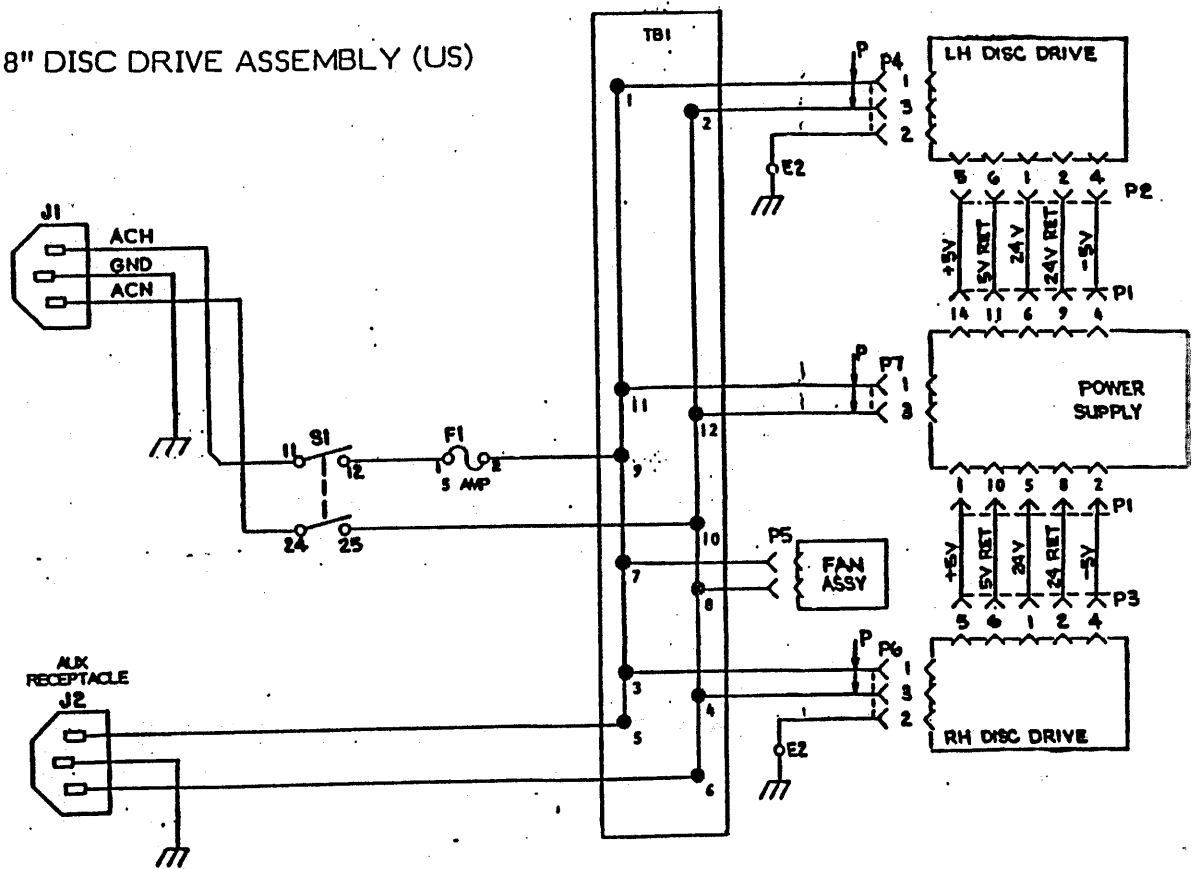

8" DISC DRIVE ASSEMBLY (RX)

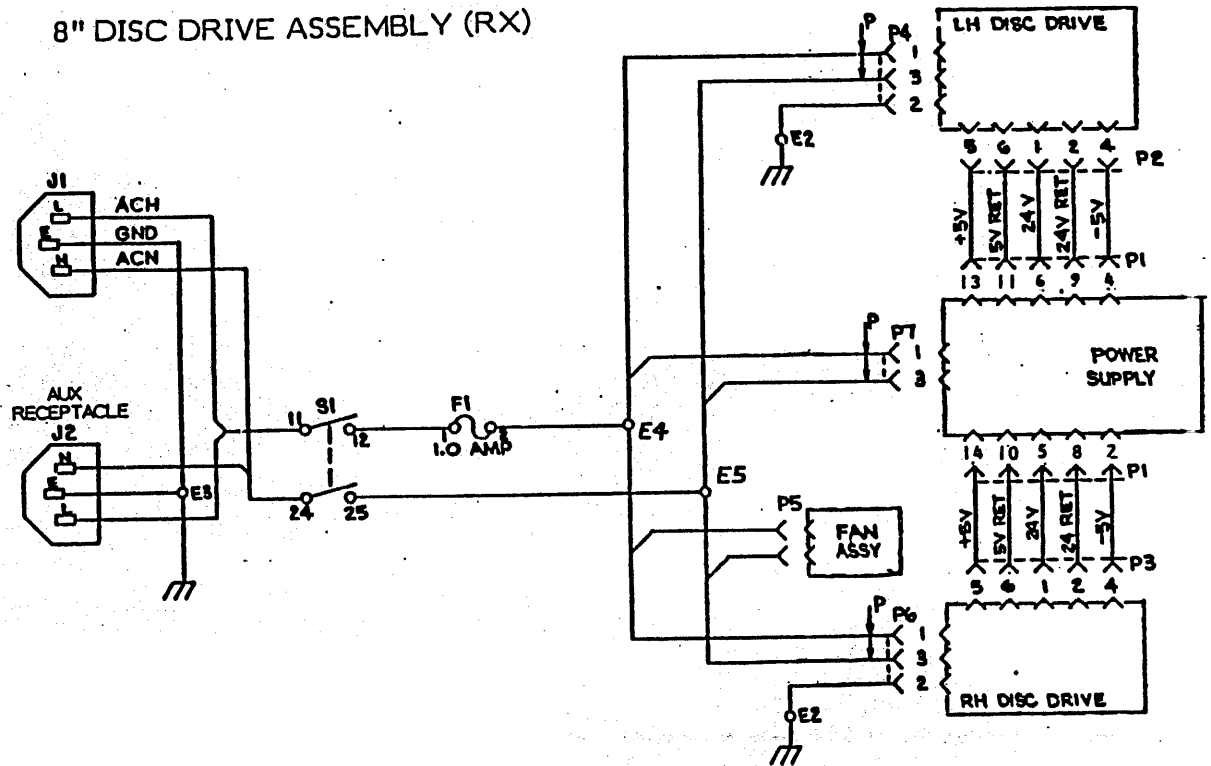

THIS PAGE INTENTIONALLY LEFT BLANK

FIXED DRIVE ASSEMBLY (US)

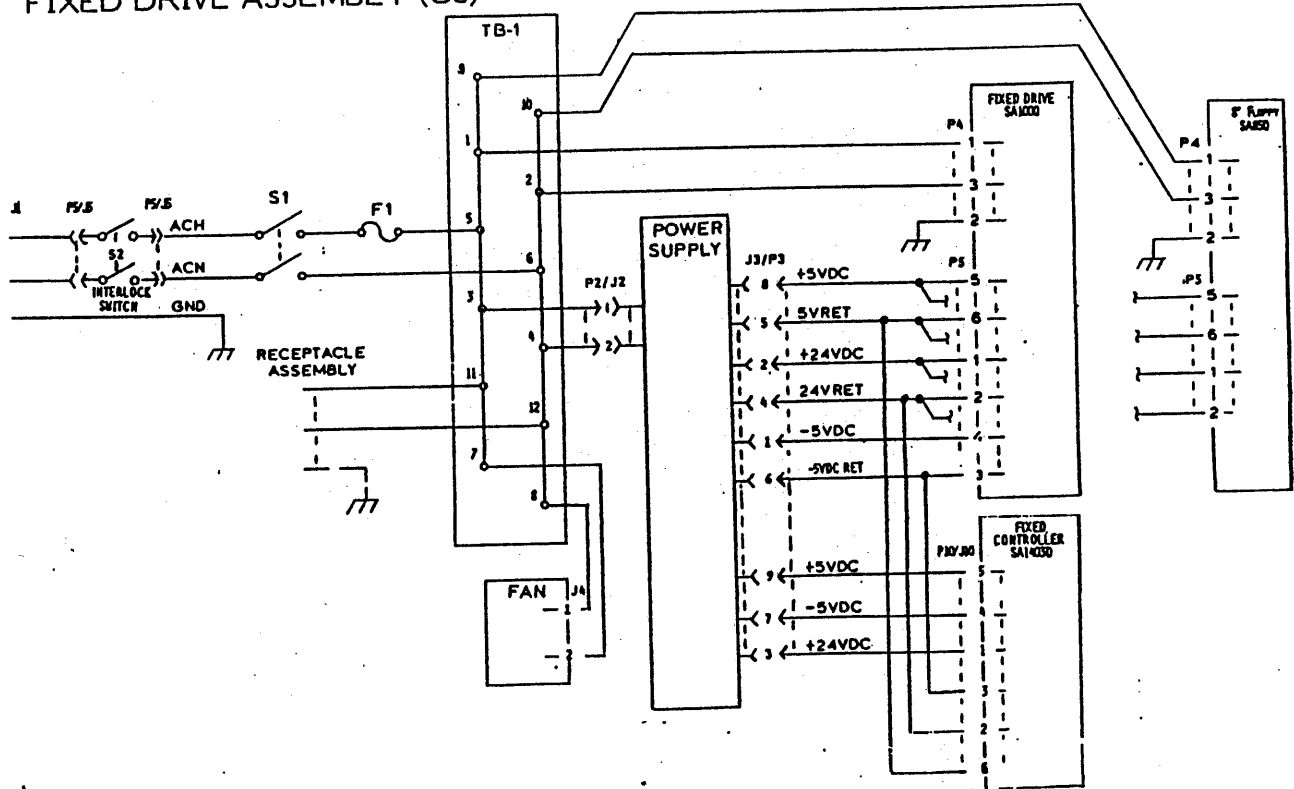

FIXED DRIVE ASSEMBLY (RX)

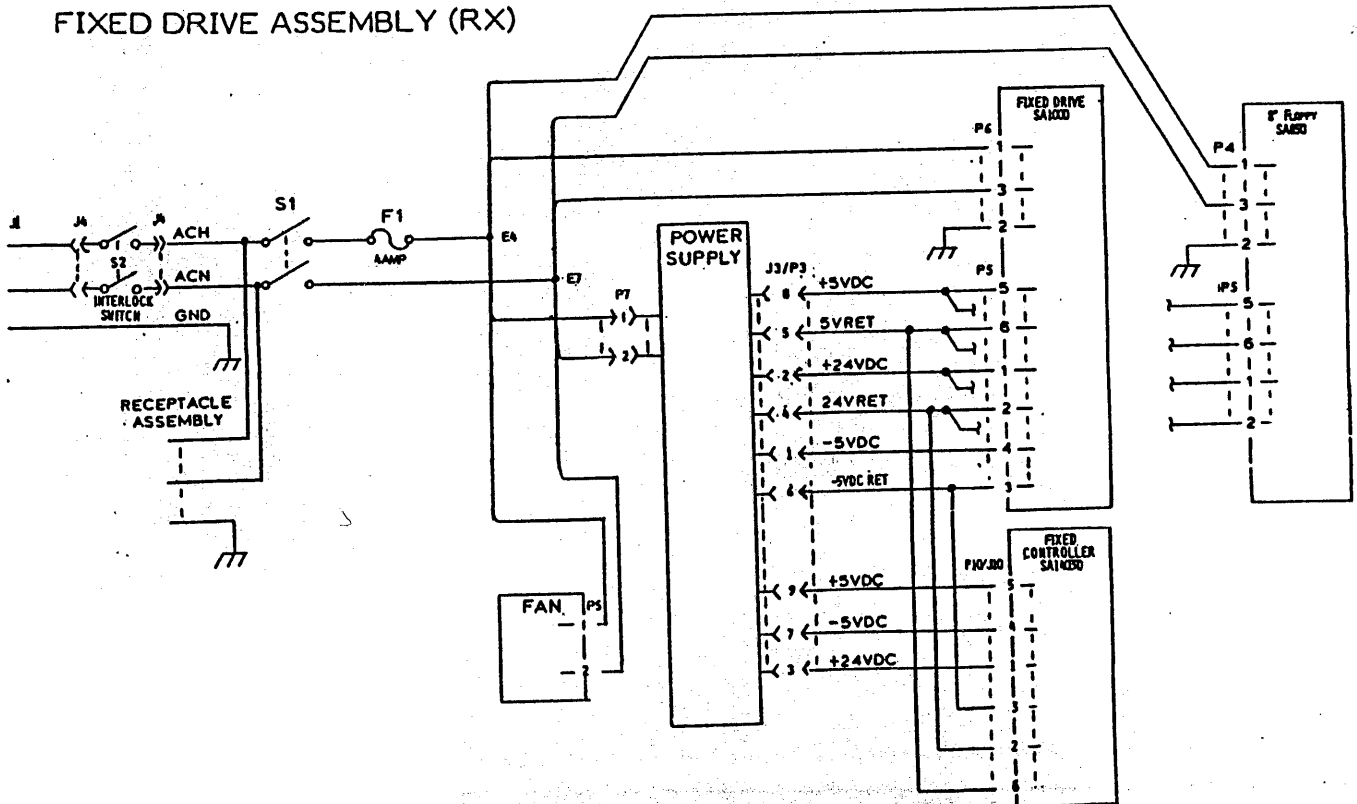

600P84592

PLUG/JACK LIST

REF	CONNECTOR	FROM	TO
1	P1/J1	Brightness Control PWA	Monitor PWA (P1/J1)
2	P1/J1	Monitor PWA	Brightness Control PWA (P1/J1) Processor PWA (P6/J6) Processor PWA (P7/J7)
3	P5/J5	Processor PWA	Power Supply (P1/J1)
4	P6/J6	Processor PWA	Monitor PWA (P1/J1)
5	P7/J7	Processor PWA	Monitor PWA (P1/J1)

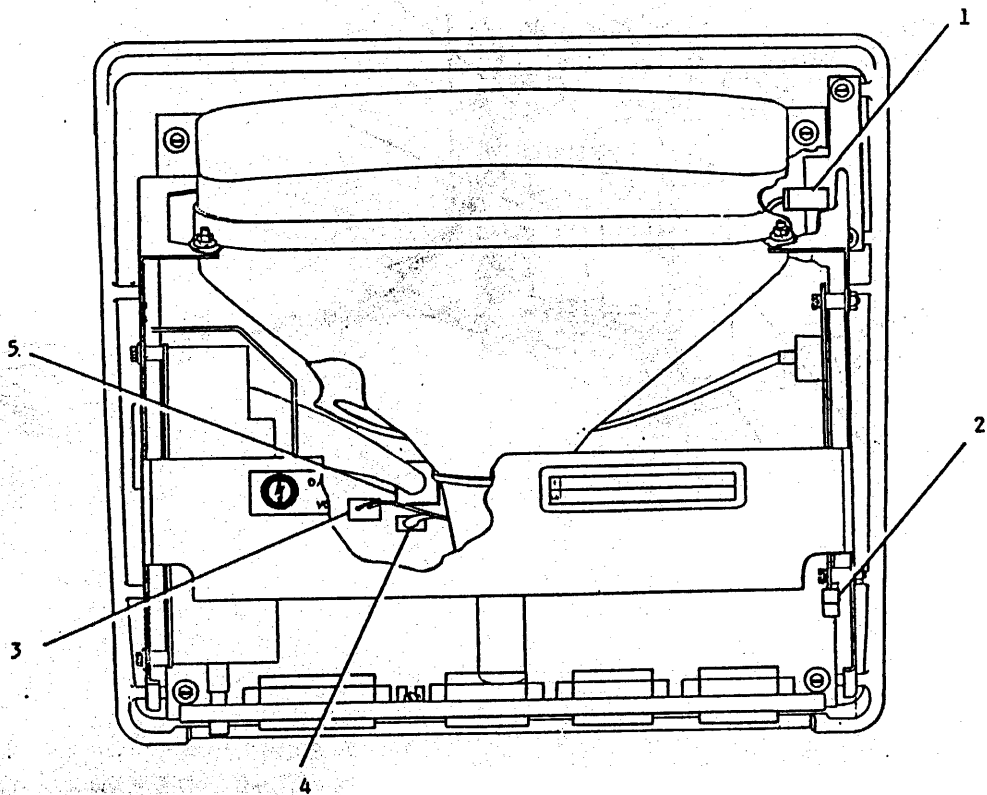

REF	CONNECTOR	FROM	TO
1	P2A/J2A	Right Drive	Processor PWA (P1/J1)
2	P2/J2	Left Drive	Right Drive (P2A/J2A)
3	P1/J1	Left Drive	Right Drive (P1A/J2A)
4	P1A/J1A	Right Drive	Processor PWA (P1/J1)
5	P3/J3	Left Drive	Left Drive PWA
6	P3A/J3A	Right Drive	Right Drive PWA

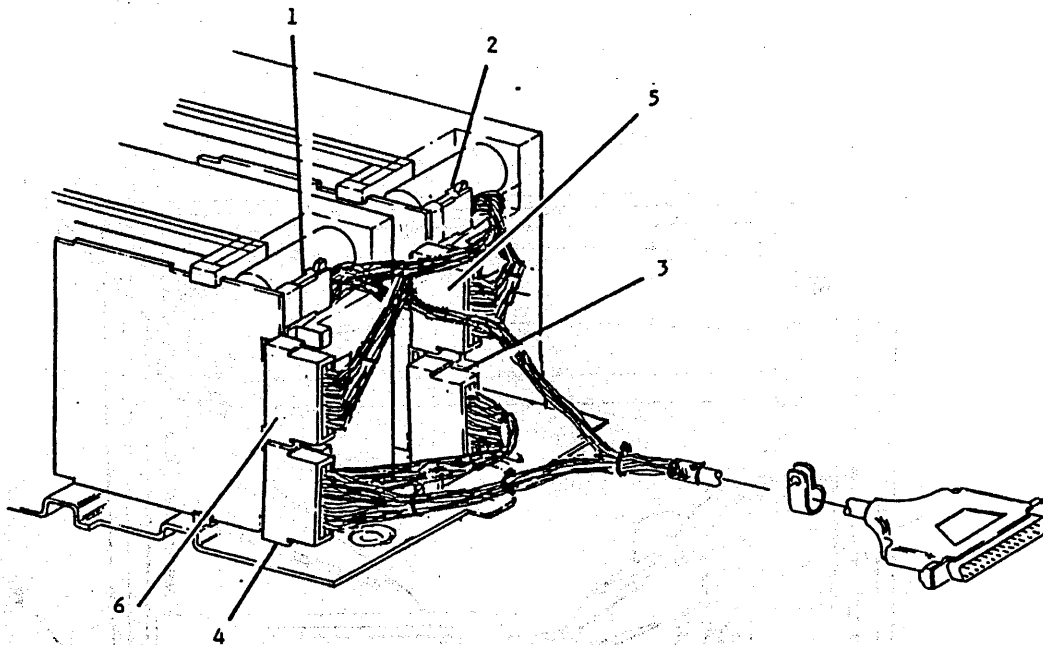

REF	CONNECTOR	FROM	TO
1	P1/J1	Power Supply	AC Power Cord Power ON/OFF SW.

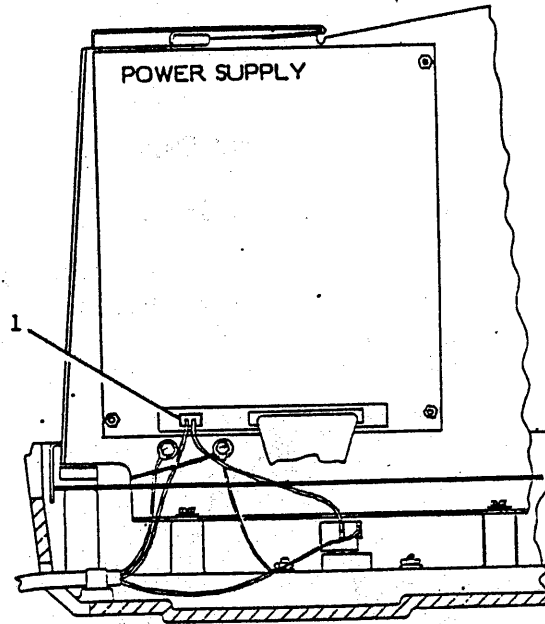

7.0 WIRE DIAGRAMS
 7.1 Plug/Jack Diagrams

600P84592
 8" Disk Drive

REF	CONNECTOR	FROM	TO
1	P2/J2	Right Drive	Power Supply (P1/J1)
2	P2A/J2A	Left Drive	Power Supply (P1/J1)
3	P1A/J1A	Left Drive	Right Drive (P1/J2)
4	P1/J1	Right Drive	Processor PWA (P1/J1)
5	P4/J4	Right Drive	Terminal Strip
6	P4A/J4A	Left Drive	Terminal Strip

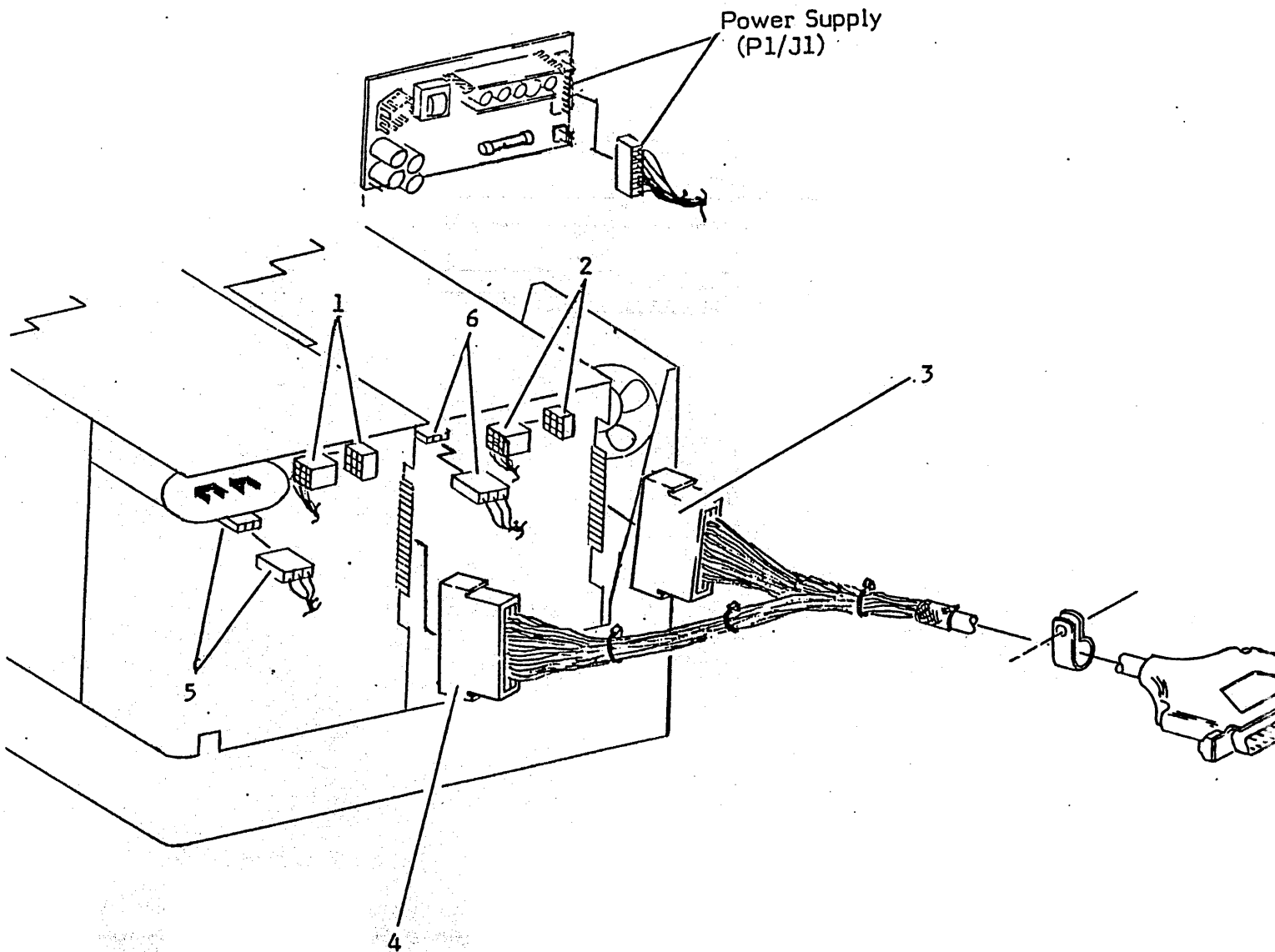

Fixed Disk Assembly

7.1 Plug/Jack Location

REF	CONNECTOR	FROM	TO
1	Power Supply Terminal Supply	Power Supply	P3/J3
2	P3/J3	Power Supply Harness	Left Drive
3	P6/J6	Left Drive	TB 1
4	A4 P5/J5	Left Drive	Right Drive A2P5/J5 Controller PWA A3 P10/J10 Connector P3/J3
5	A4 P1/J1	Left Drive	Controller PWA A3 P1/J1 Right Drive A2 P1/J1
6	TB 1	Located under Cooling Fan	Distributes AC Power to: Fan Assembly B1 Left Drive A4 P4 Power Supply P2/J2 Right Drive A2 P4/J4 Top Cover Interlock SW P5
7	A3 P1/J1	Controller PWA	Right Drive A4 P1/J1 Left Drive A2 P1/J1
8	P1	Controller PWA	Processor PWA
9	A3 P10/J10	Controller PWA	Power Supply Harness P3/J3 Right Drive A2 P5/J5 Left Drive A4 P5/J5
10	A3 P6/J6	Controller PWA	Signal Harness: P1
11	A2 P1/J1	Right Drive	Controller PWA A3 P1/J1 Left Drive A4 P1/J1

7.1 Plug/Jack Location

Fixed Disk Assembly

REF	CONNECTOR	FROM	TO
12	A2 P5/J5	Right Drive	Power Supply Harness P3/J3 Controller PWA A3 P10/J10 Left Drive A4 P5/J5
13	P5/J5	Interlock Switch	TB 1
14	P4/J4	Right Drive	TB 1 Left Drive P6/J6
15	A1 P1/J1	Stepper PWA	Right Drive A2 P9/J9
16	A2 P3/J3	Right Drive	Fixed Drive Track Selector Motor
17	A2 P7/J7	Right Drive	Right Drive Read/Write Head
18	A2 P8/J8	Right Drive	Right Drive Read/Write Head
19	A2 P9/J9	Right Drive	Stepper PWA A1 P1/J1
20	A2 P2/J2	Right Drive	Controller PWA A3 P2/J2
21	A3 P2/J2	Controller PWA	Right Drive A2 P2/J2
22	J2/P2	Power Supply Terminal Strip	TB 1

7.0 WIRE DIAGRAMS

7.2 Plug/Jack Terminal Identification

600P84592

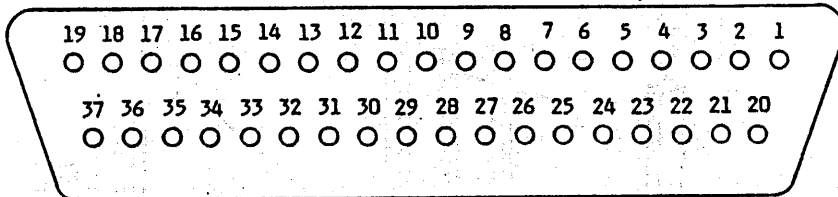
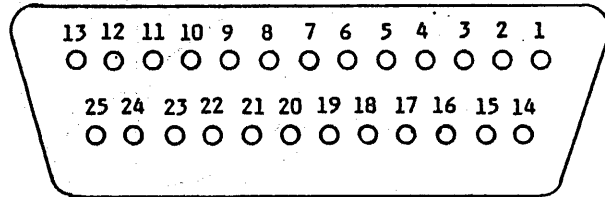
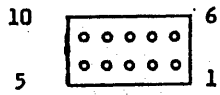
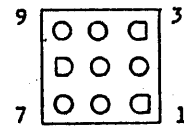
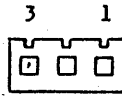

7.0 WIRE DIAGRAMS
7.3 WIRE RUN LISTS

600P84592

8" DISC DRIVE ASSEMBLY (US)

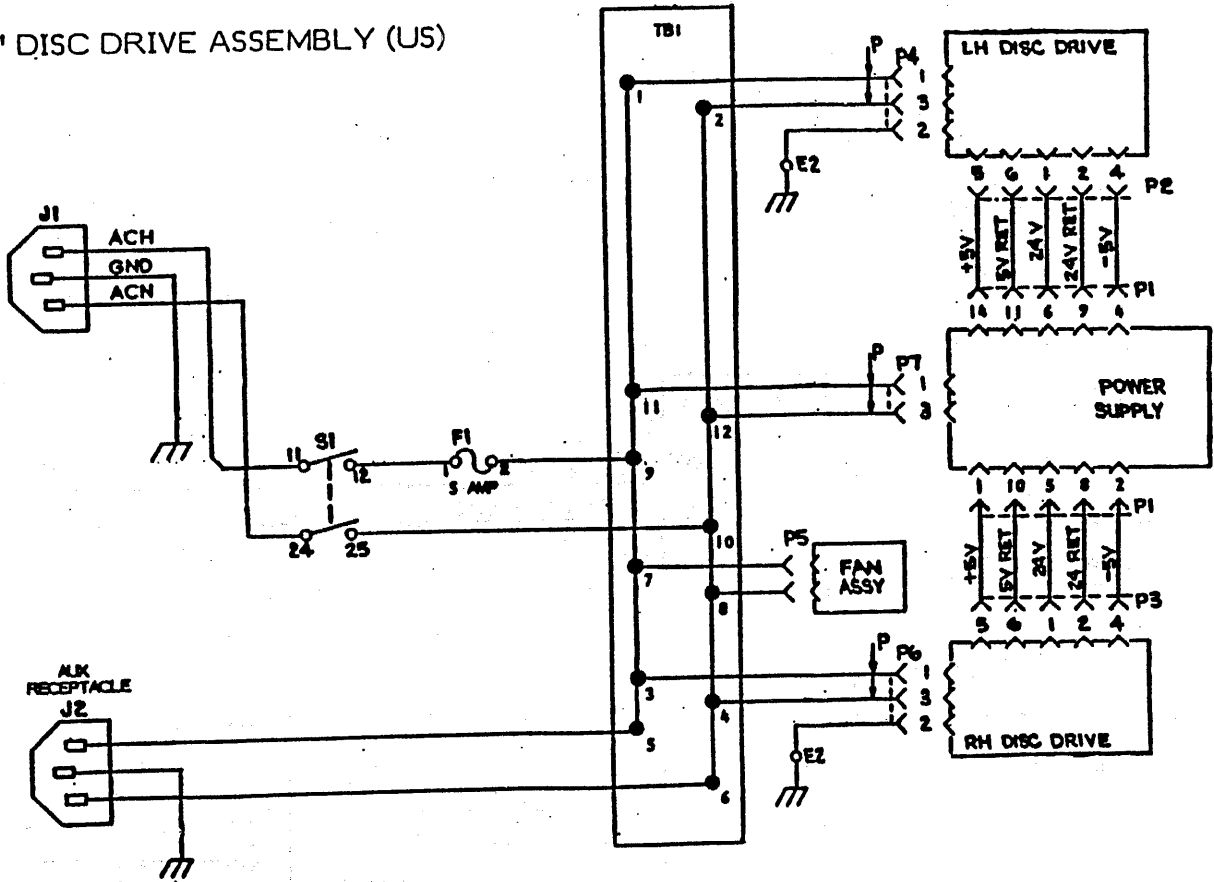

8" DISC DRIVE ASSEMBLY (RX)

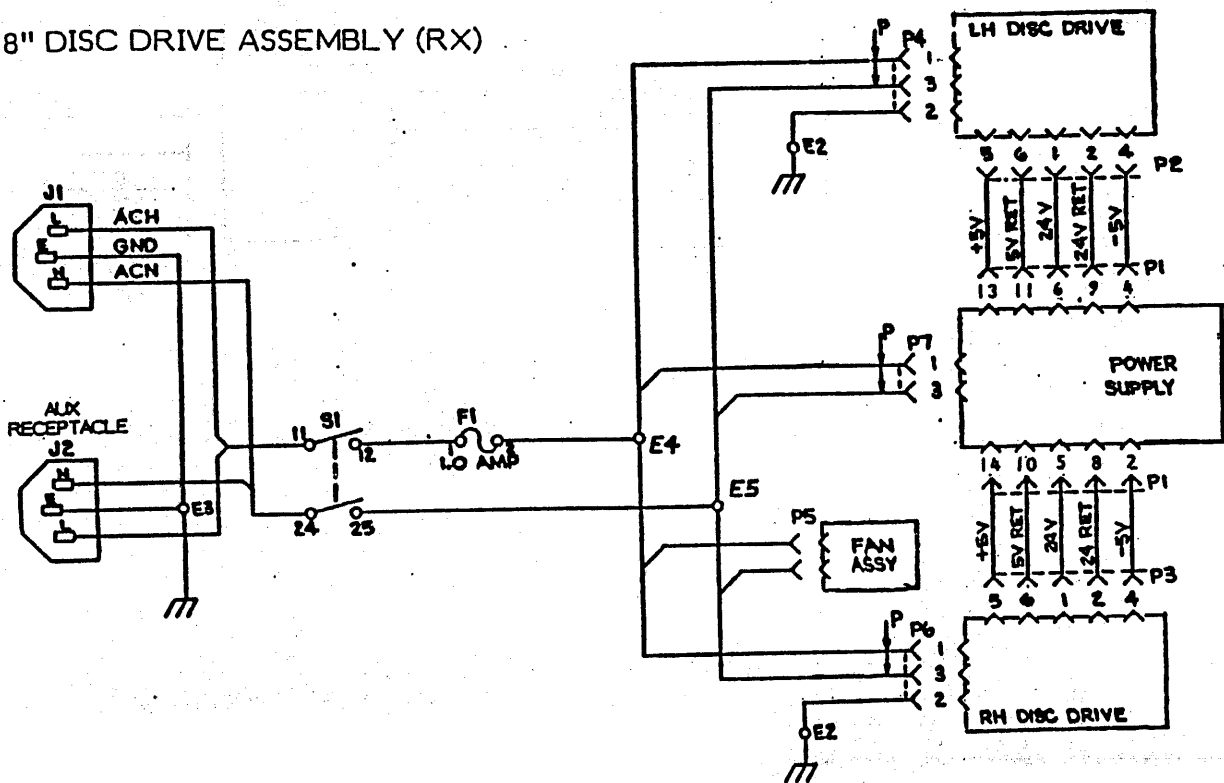

FIXED DRIVE ASSEMBLY (US)

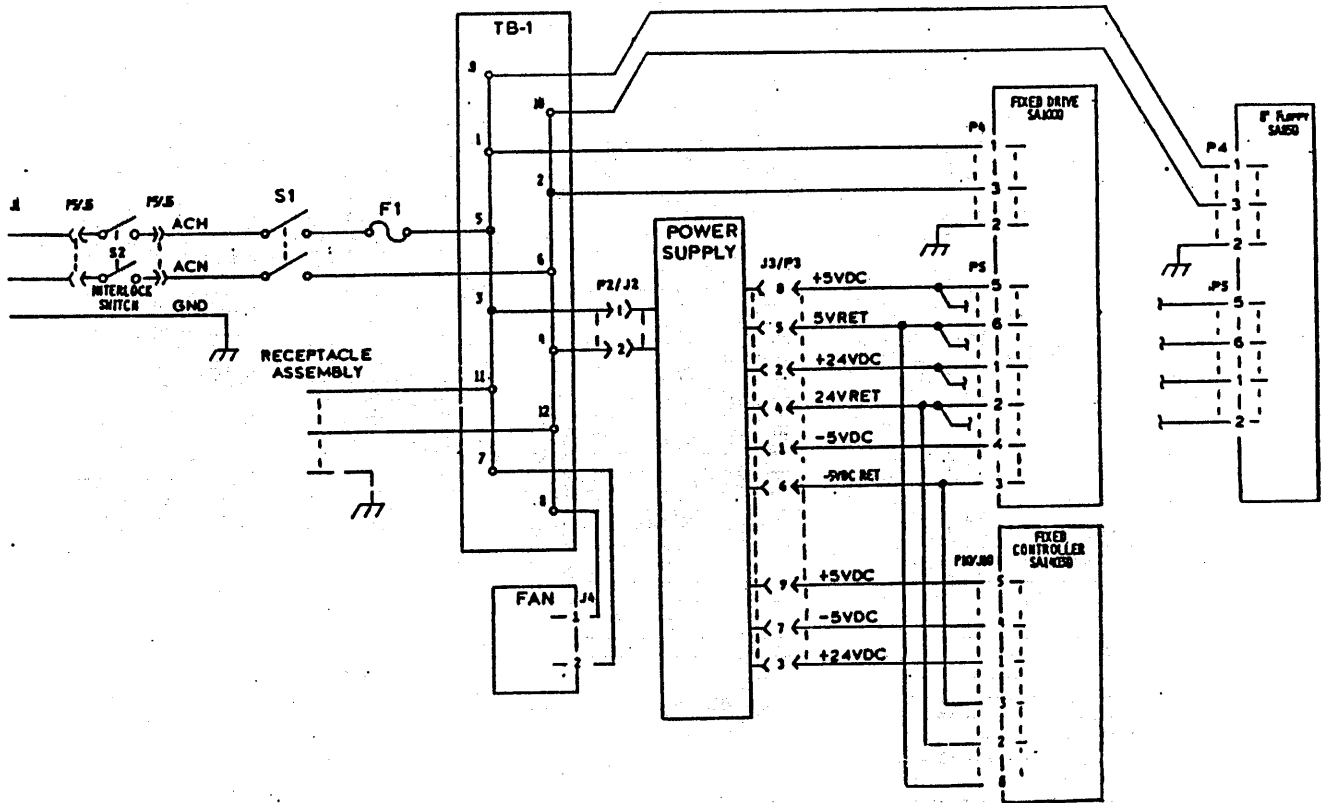

FIXED DRIVE ASSEMBLY (RX)

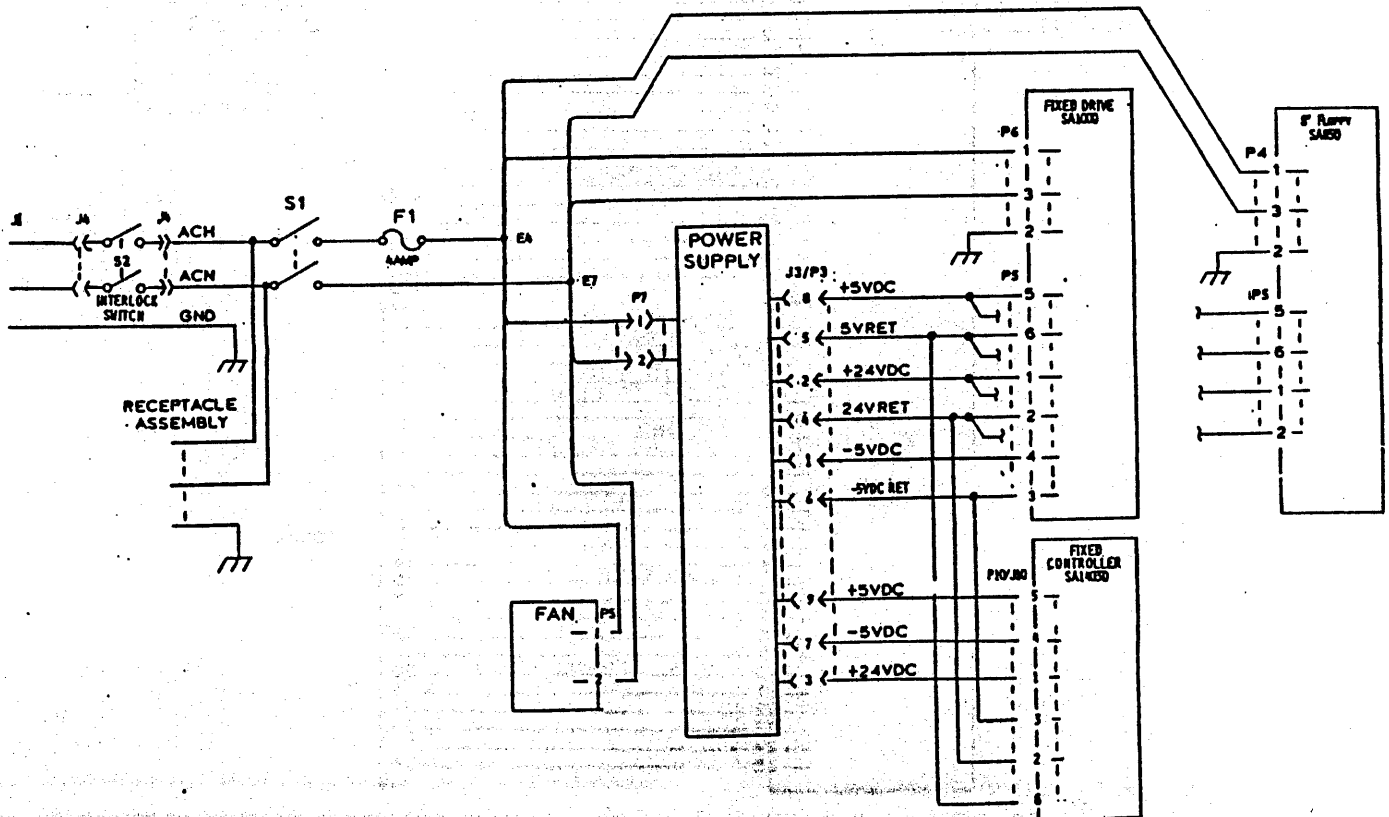

7.0 WIRE DIAGRAMS

7.3 Wire Run Lists

600P84592

FIXED DRIVE SYSTEM

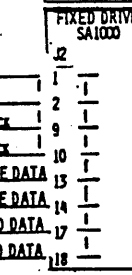
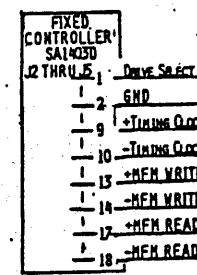
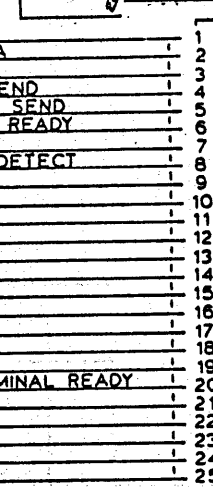
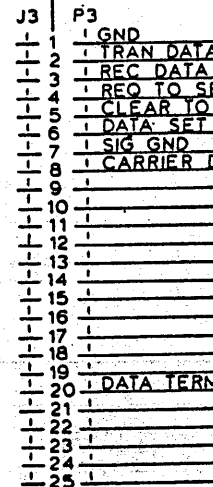
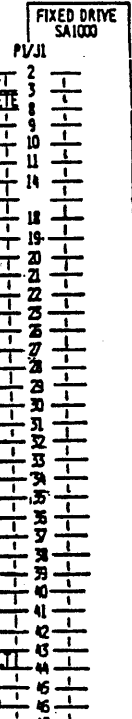
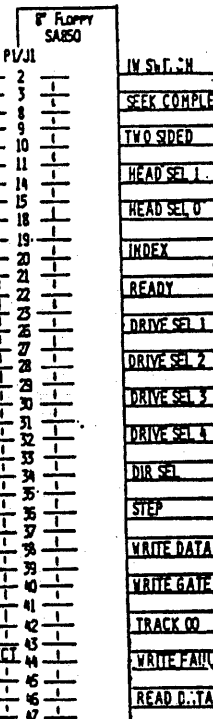
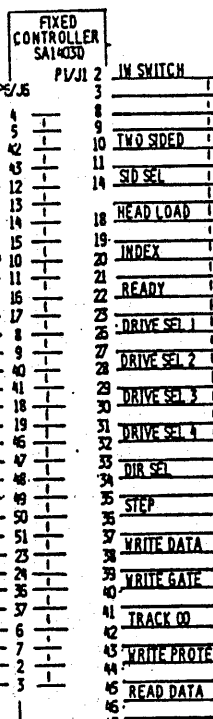
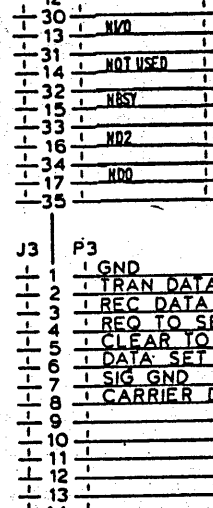
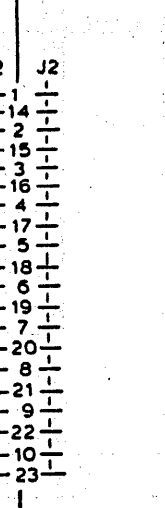
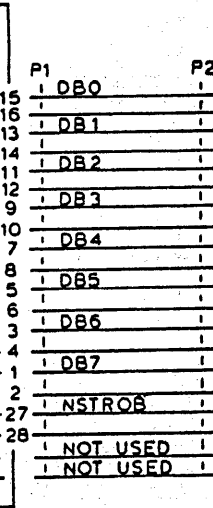
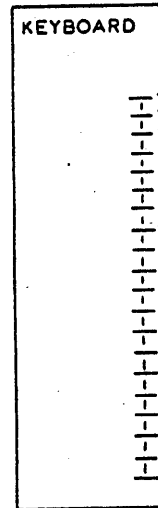
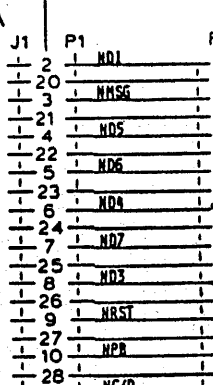
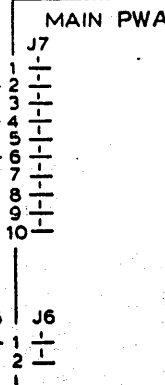
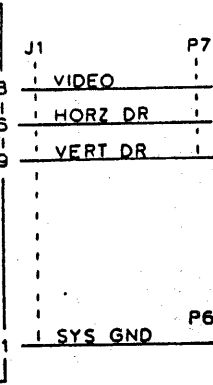
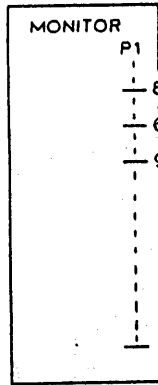

SERIAL PRINTER

COMM

5.25" and 8" FLOPPY DRIVE SYSTEM

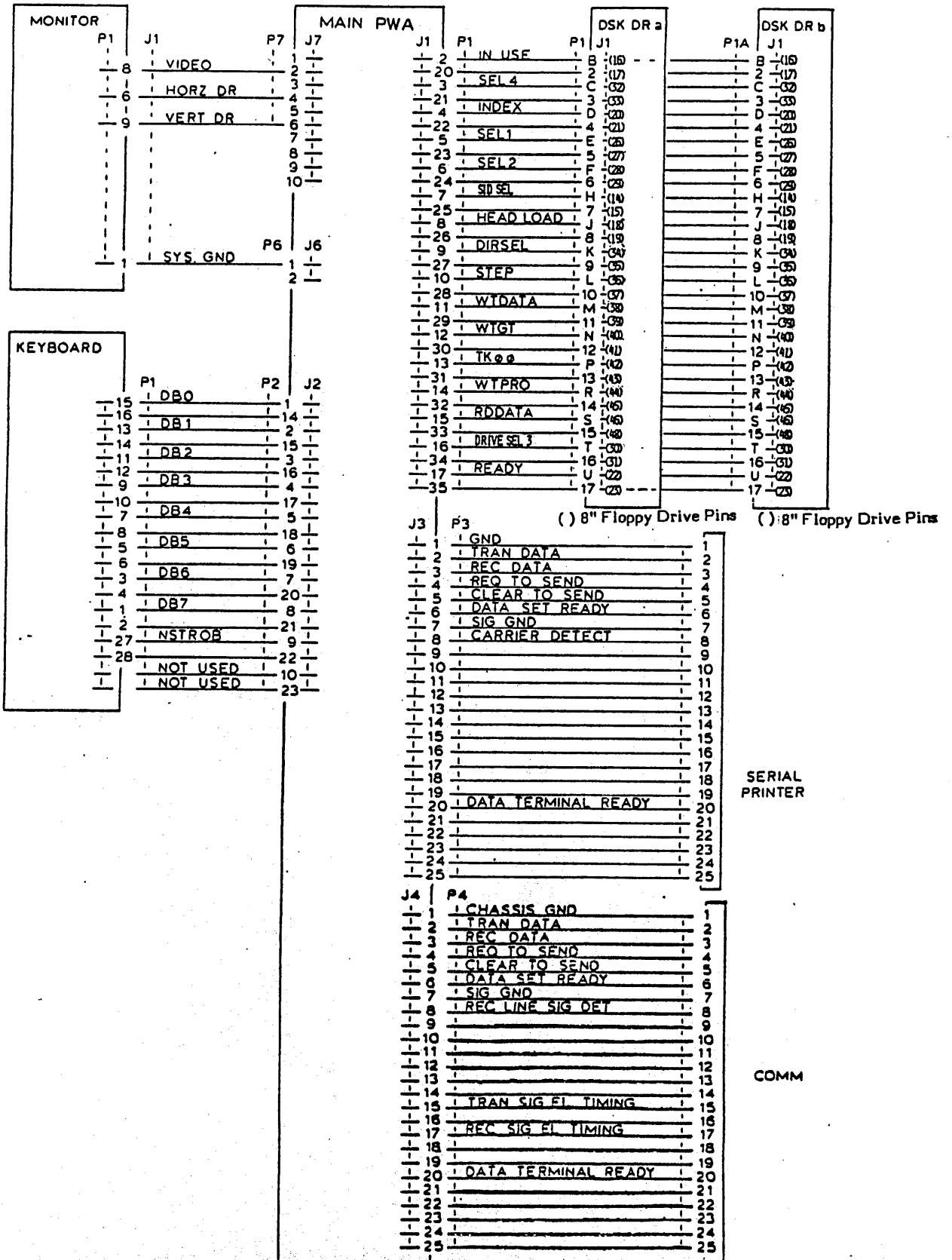

THEORY OF OPERATION

XEROX 820/820-II MICROPROCESSER

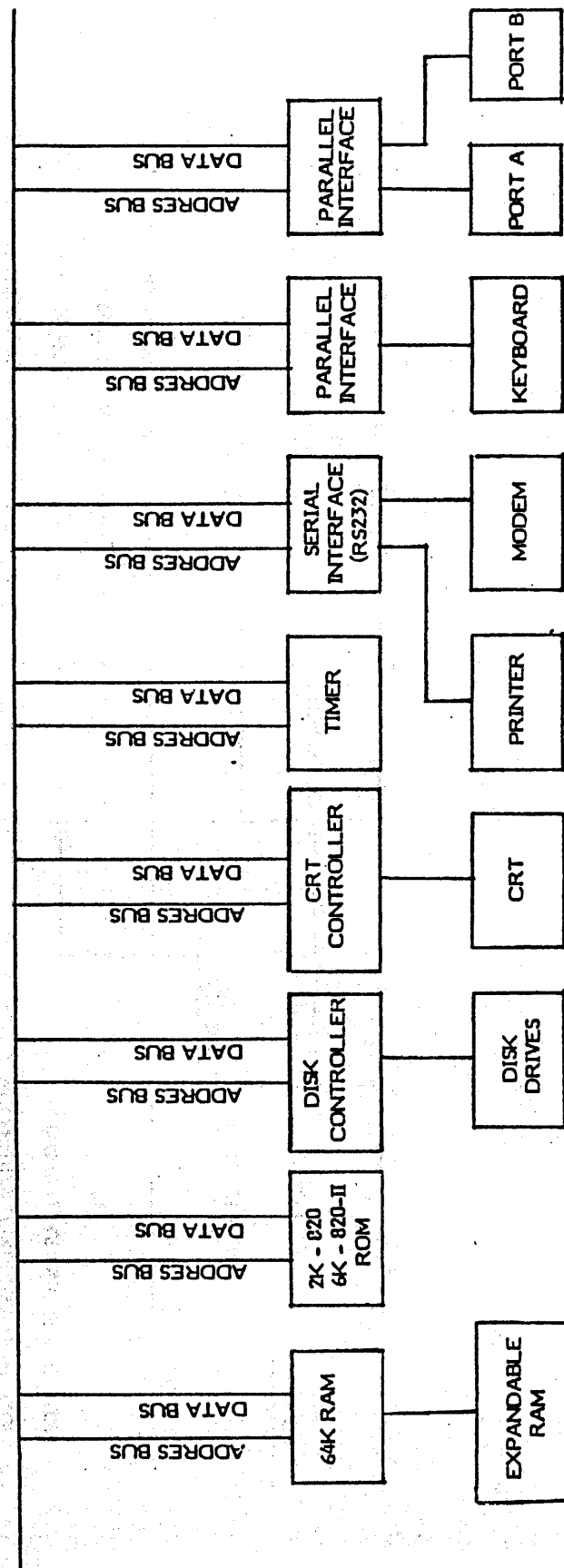

FIG. 8-1

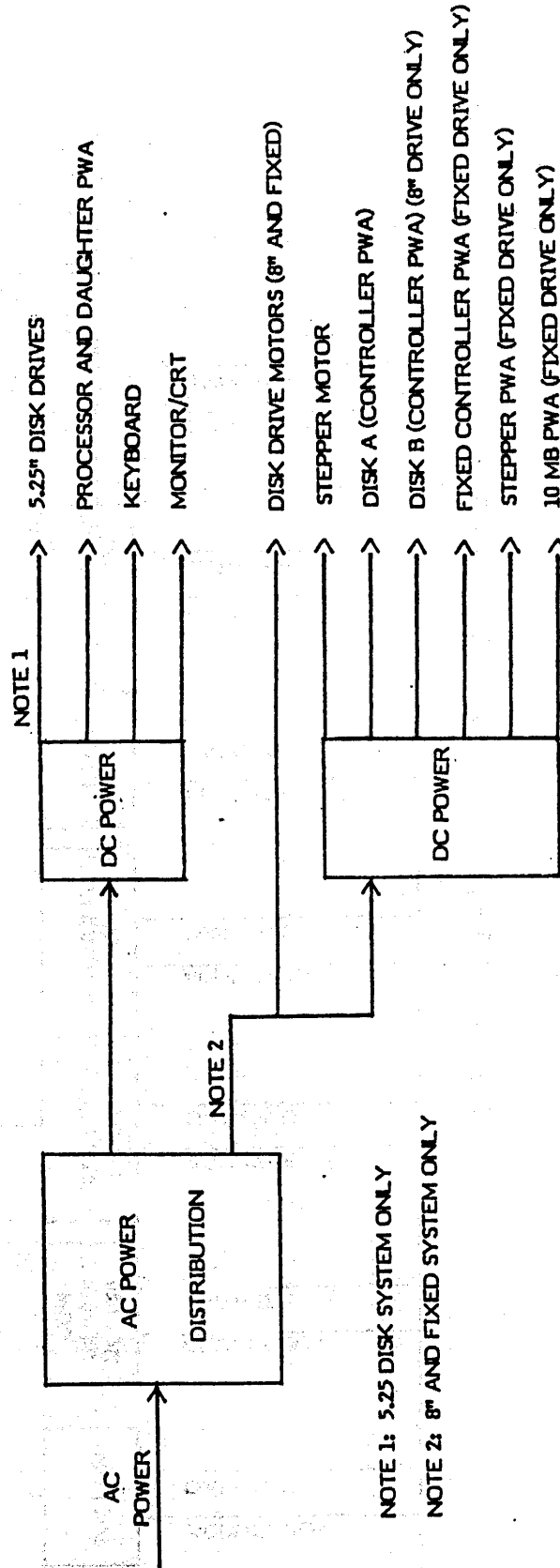

FIG. 8-2

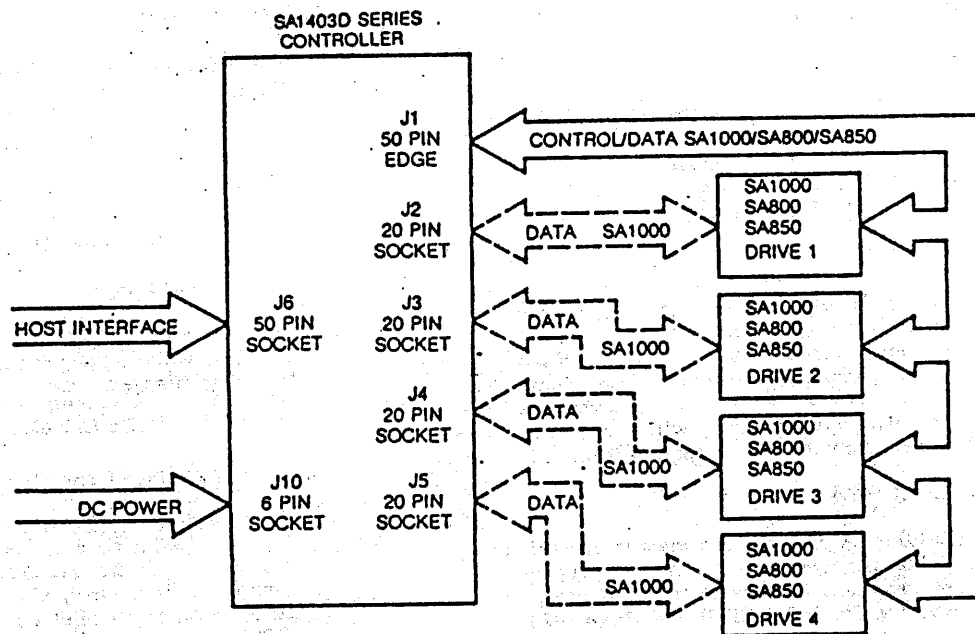

Figure 8-3 SA1403D INTERCONNECT DIAGRAM

8.1 General

The 820 family is a table top microcomputer composed of the following assemblies:

820 IP Processor

1. D.C. Power Supply
2. Processor (CPU) PWA.
3. CRT Assembly
4. Keyboard Assembly

820 IP - SA400 (5.25" Single Sided Floppy Drive)
 820 IP - SA800 (8" Single Sided Floppy Drive)
 820 IP - SA450 (5.25" Dual Sided Floppy Drive)
 820 IP - SA850 (8" Dual Sided Floppy Drive)

820-II Processor

1. D.C. Power Supply
2. Processor (CPU) PWA
3. Floppy Disk Daughter PWA or,
Fixed Disk Daughter PWA
4. CRT Assembly
5. Keyboard Assembly

820-II IP - SA400 (5.25" S.S. Dual Density Floppy Drive)
 820-II IP - SA800 (8" S.S. Dual Density Floppy Drive)
 820-II IP - SA450 (5.25" D.S. Dual Density Drive)
 820-II IP - SA850 (8" D.S. Dual Density Floppy Drive)
 820-II IP - SA1000 (10 MB Fixed Drive)

8.2 D. C. Power Supply

The D. C. Power Supply converts the AC supply input to three DC voltages required by the system. These voltages are +5, +12 and - 12VDC. Each voltage has short circuit protection by electronic current limiting. When any of the outputs are overloaded the entire Power Supply will shut down. The +5VDC is provided with overvoltage protection.

8.3 Processor (CPU) PWA

The processor (CPU) PWA provides the master control for the system. The Microprocessor is the central processing unit. It executes programs (software) that are stored in the 64K Ram and the 2K ROM (820), 6K ROM (820-II). The 820 IP incorporates a Z80 Microprocessor where as the 820-II IP incorporates a Z80A. Added features of the 820-II IP processor are:

- A. 4 MHz Clock
- B. 2-RS232 Ports (one dedicated to serial printer)
- C. 820 System Bus Access
- D. Audible Alarm
- E. Video Highlighting
- F. 6K ROM Expansion Capacity
- G. 2-Fixed Disc Drive Options:
SA606 and SA450
SA1004 and SA850
- H. Ethernet Connection (via 872/873 Comm Server)
- I. 2-Buffered 8 Bit Parallel ports
- J. Display Graphics

The CPU is supported by five intelligent peripheral controllers. These devices handle the tasks of transferring the data to and from the peripheral devices, thus relieving the burden on the CPU.

A. Disc Controller

This device (On the 820-II, it is located on the Daughter PWA for the floppy or the fixed) interprets commands from the CPU and generates appropriate control signals for the disc drives. It also interprets status signals from the disc drives and delivers them to the CPU upon request. The second function is to convert parallel data from the Data Bus to serial data suitable for recording on the disc and also the conversion from the serial data read from the disc to parallel data suitable to the CPU. The fixed drive assembly contains a 1403D Controller PWA that in effect tells the system what type of drives are being used (SA800, SA850, or SA1004).

B. CRT Controller

The devices that make up the CRT Controller provide interface for the display and CPU. The CRT Controller will convert data from the system data bus into Horizontal Sync, Vertical Sync and Video signals used by the display. The CRT Controller also handles the task of scrolling characters up the screen.

C. Timer Controller

The timer controller's function is to signal the CPU when a pre-programmed amount of time has elapsed. One of the uses of this timer is the 30 second delay before turning off the 5.25" Disc Drives.

D. Serial Interface Controller

This device handles the conversion of the CPU's parallel data to serial data required for serial printers and data communications equipment (modems), also the conversion of serial data to parallel data suitable for the CPU. The controller also provides status information from the external serial device to the CPU. Modem control commands from the CPU are generated by this controller.

E. Parallel Interface Controller

This device is used as an interface between the CPU and the parallel keyboard. It also generates some control signals used as Disc Drive selects and memory bank selecting.

8.4 DISC DRIVES (5.25")

The left and right disc drives are identical except for the placement of jumpers/resistor networks on the disc drive PWA's. Each of the Floppy Disc Drives contains the following.

1. DC Drive Motor
2. DC Head Stepper Motor
3. Read/Write Head
4. Head Load Solenoid And Load Pad.
5. Track - Detector Switch

8.5 Disk Drives (8") 8.6 CRT Assembly 8.7 Keyboard Assembly

6. Index Led/Detector
7. Write Protect Switch
8. Control PCB
9. Drive Indicator LED

DC Power is constantly supplied through the disc interface harness from the power supply in the processor. The DC drive motor is turned on when the appropriate control signal is active from the processor PWA. The disc drives receive control signals through the disc signal harness from the Floppy Disc Controller on the processor (CPU) PWA. These control signals select the appropriate disc drive, control the head stepper motor, the head load solenoid and select read or write modes.

The disc drives send the following status information through the disc signal harness to the Floppy Disc Controller on the Processor (CPU) PWA:

1. Ready (Floppy disc loaded and at speed)
2. Index (Index hole sensed)
3. Track 00 (Read/Write Head positioned on Track 0)
4. Write protect (Write protected disc loaded in the drive)

The function of the Disc Drives is to magnetically record (write) data on a floppy disc, and to play back (read) information that had previously been stored on a floppy disc.

8.5 DISC DRIVES (8")

The left and right Disc Drives are identical except for the placement of jumpers on the disc drive PWA.

Each of the Floppy Disc Drives contains the following:

1. AC Drive Motor
2. DC Head Stepper Motor
3. Read/Write Head
4. Head Load Solenoid and Load Pad
5. Track 00 LED/Detector
6. Index LED/Detector
7. Write Protect LED/Detector
8. Control PWA
9. Drive Indicator LED

AC power is constantly supplied through the Disc AC power cord to the drive motors from the AC Power Distribution Panel when the power on switch is on. The disc rotational speed is 360 rpm. The drive pulleys and belts are different sizes for the USN/XC systems (60Hz) and the RX systems (50 Hz) in order to obtain the 360 rpm speed.

The Internal Supply supplies DC power (+5 VDC, -5 VDC, +24 VDC and GND) through the Disc DC Harness. The DC power is used for the logic circuits and driver/receiver circuits on the PWA's. The Disc Drives receive control signals through the Disc Signal Harness from the Floppy Disc Controller on the Processor CPU PWA. These control signals select the appropriate Disc Drive, control the Head Stepper Motor, the Head Load Solenoid, and select Read or Write modes.

The Disc Drives send the following status information through the Disc Signal Harness to the Floppy Disc Controller.

1. Ready (Floppy Disc loaded and at speed)
2. Index (Index hole sensed)
3. Track 00 (Read/Write Head positioned on Track 0)
4. Write Protect (Write protected disc loaded in the drive)

The function of the Disc Drives is to magnetically record (write) data on a floppy disc, and to play back (read) information that had previously been stored on a floppy disc.

8.6 5.25" AND 8" DUAL SIDED

The SA450 and SA850 Disc Drives are also used on the 820 Family. The functions are the same as the SA400 and the SA800 with the exception of a additional signal "side select" thus allowing the Dual sided 5.25" drives to have 80 tracks and the dual sided 8" drives to have 154 tracks. On the 820-II Processor, we have double density capability. This is obtained by the use of MFM (modified frequency modulation) and M2FM (modified, modified frequency modulation) rather than FM, which is the standard method of encoding data on the diskette. This causes the write oscillator frequency to double. Data transfer rate is also doubled. Thus we now have dual sided, double density which is approximately four times the capacity of a single sided, single density.

8.7 CRT ASSEMBLY

The CRT Assembly contains a complete CRT monitor requiring only DC Power, horizontal and vertical Sync and video inputs.

The CRT has a 12 inch screen with a display capability of 24 lines of 80 characters per line. The Video rate is 15MHz.

The 820-II has Business Graphics made possible by a 4*4 Pixel Resolution. It has two sets of 128 character sets (1 U.S. FONT, 1 GRAPHIC FONT), plus the capabilities for 2 additional sets. The 820-II also has Character Blinking and Highlighting. The RX units have a INTERNATIONAL FONT.

8.8 KEYBOARD ASSEMBLY

The Keyboard provides the keyswitches that upon activation generate the appropriate ASCII code to the parallel interface controller on the CPU PWA.

8.9 1403D DISC DRIVE CONTROLLER

The SA1403D Controller (located in the Fixed drive box assembly) consists of a microprocessor based controller with on-board data separator logic and is able to control a maximum of four drives. The drives can be any combination of Shugart SA1000 fixed drives, SA800 or SA850 floppy disk drives. Data is transferred to and from the controller over a 7 bit with parity bidirectional bus connected to the Processor. The data separator logic serializes bytes and converts to FM/MFM data, to send to the selected Disc Drive and deserializes FM/MFM data into 8-bit bytes to send to the Processor. The command and status information is passed between

8.0 THEORY OF OPERATION

8.10 FIXED DISK ASSEMBLY 8.11 CP/M INTRODUCTION

the processor and 1403D controller on Unidirectional Signals Busy, Acknowledge, Reset, Message, Select, Control Data, Request, and Input/Output.

Shugart SA800/SA850 disc drives are interfaced via J1. Shugart SA1000 disc drives are interfaced via J1, J2, J3, J4, and J5 with the processor is interfaced via J6. The Processor is interfaced via J6. Refer to Figure 8-3 in the Theory Of Operations in your service manual for connection block diagram.

8.10 FIXED DISC ASSEMBLY

The Fixed DISC Assembly contains two discs, a power supply and the fixed controller PWA.

The Fixed Controller PWA is the SA 1403D described in the disc:controller section.

The Internal Power Supply, similar to the 8" disk power supply, supplying DC power (+5 VDC, -5 VDC, +24 VDC and GND) to both disks through the DC harness. The DC power is used for logic circuits, driver/receiver circuits, head write current, and the DC stepper motor control, on both disc drives.

The left disc is a SA 850 (Dual Sided Double Density) floppy drive. This is the same floppy drive as used in the 8" (Dual Sided) disk assembly, consisting of the same sub-assemblies. The floppy drive has the same interface as in the 8" assembly except it communicates with the Fixed Controller and the Fixed Controller then interfaces with the 820 Processor.

The right disc is a SA 1004 disk drive. This is a Shugart, 2 platter, 4 head 10 mega byte fixed disc drive. This disk drive contains the following:

1. The sealed 2 platter 4 head with stepper motor and Idex transducer assembly
2. The Damper
3. The Stepper PWA
4. Track 00 Flag Assembly
5. 10 MB Control PWA
6. AC drive motor with capacitor
7. Motor pulley and belt

AC power is constantly supplied through the disk AC harness to the drive motor from the AC power distribution panel when the power switch is on.

The fixed drive, like the floppy, interfaces to the fixed controller PWA. Then the fixed controller communicates to the CPU. The fixed drive sends the following signals to the fixed controller:

1. Drive Selected (drive's acknowledgement to Drive Selected 1, 2, 3, or 4)
2. Ready (drive up to speed 3125 rpm and no error exists)
3. Index (Inductive pickup sensor)
4. Seek Complete (head positioned on specified track)
5. Track 00 (heads positioned on track 00)
6. Write Fault (1. Write current in heads with no write gate from fixed controller; 2. Multiple head select)

7. Read Data (MFM)

The fixed controller sends the following signals to the fixed drive:

1. Drive select 1, 2, 3 or 4 (drive select 4 for fixed, drive select 1 for floppy)
2. Step (commands the stepper motor to move the read/write heads)
3. Direction select (defines the direction the read/write heads will move on a step command)
4. Head select 0 and head select 1 (selects the specific head through binary decode)

<u>Sel. 0</u>	<u>Sel. 1</u>	<u>Head</u>
Off	Off	0
On	Off	1
Off	On	2
On	On	3

5. Timing Clock (synchronizes data transfer)
6. Write Gate (enables write current to read/write heads)
7. IW Switch (changes the amount of current due to a need for more current on the outer tracks of the disk. The switch point is at track 128)
8. Write Data (MFM)

Through handshaking of the above signals the drive performs its function of magnetically recording data on the fixed platter and to play back the information that had previously been recorded.

8.11 CP/M INTRODUCTION

The 820 processor is designed to accommodate the CP/M (Control Program for Microcomputers) operating system. The function of any operating system is to manage the hardware resources (Keyboard, Printer, Display) and provide file management capabilities for the application program intended to be executed on the system.

CP/M is logically divided into four distinct modules:

BIOS (Basic Input/Output System). These are the low level software drivers for the different hardware devices connected to the system. The BIOS is brought into memory at boot time and remains resident until power is removed. The BIOS is used by the BDOS. Typical BIOS functions are select disk, set track, set sector read sector, write sector, get keyboard input and print character printer. The BIOS is usually different on other types of CP/M compatible computers, because of the mechanisms to select discs, print characters etc may be different. The BIOS occupies 512 Bytes memory.

BDOS (Basic Disc Operating System). Like the BIOS the BDOS is read from disc into memory at boot time and remains resident until power is removed. Application Programs (word processing, basic interpreters etc.) interface with the BDOS to utilize the hardware resources attached to the system (print characters, display characters, open disk file close disk files etc.). The BDOS in turn interfaces

with the BIOS to accomplish the desired task. The BDOS occupies 3456 Bytes of memory.

CCP (Console Command Processor). The CCP allows the user to view the disc directory, erase files and rename files. The CCP can be overlaid by applications programs. The CCP is used to get the applications program off of the disk into memory to be executed, at this point the CCP is no longer needed as all operating system interface is through BDOS. The CCP occupies 1920 Bytes of memory.

TPA (Transient Program Area). This is the area in memory that applications programs are executed from.

The CP/M operating system provides excellent transportability of software from system to system regardless of the hardware configuration.

NOTE: CP/M is a trademark of Digital Research Inc.

SCHEMATIC

DIAGRAMS

820 CPU

XEROX 820/820-II MICROPROCESSER

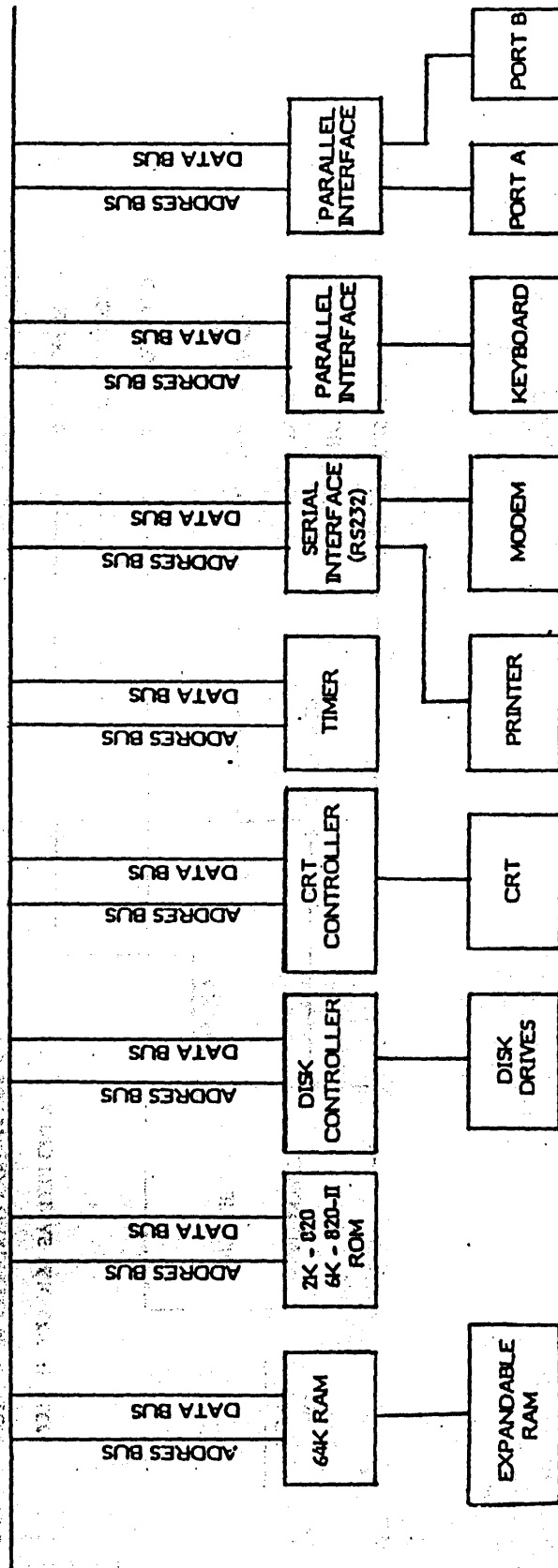
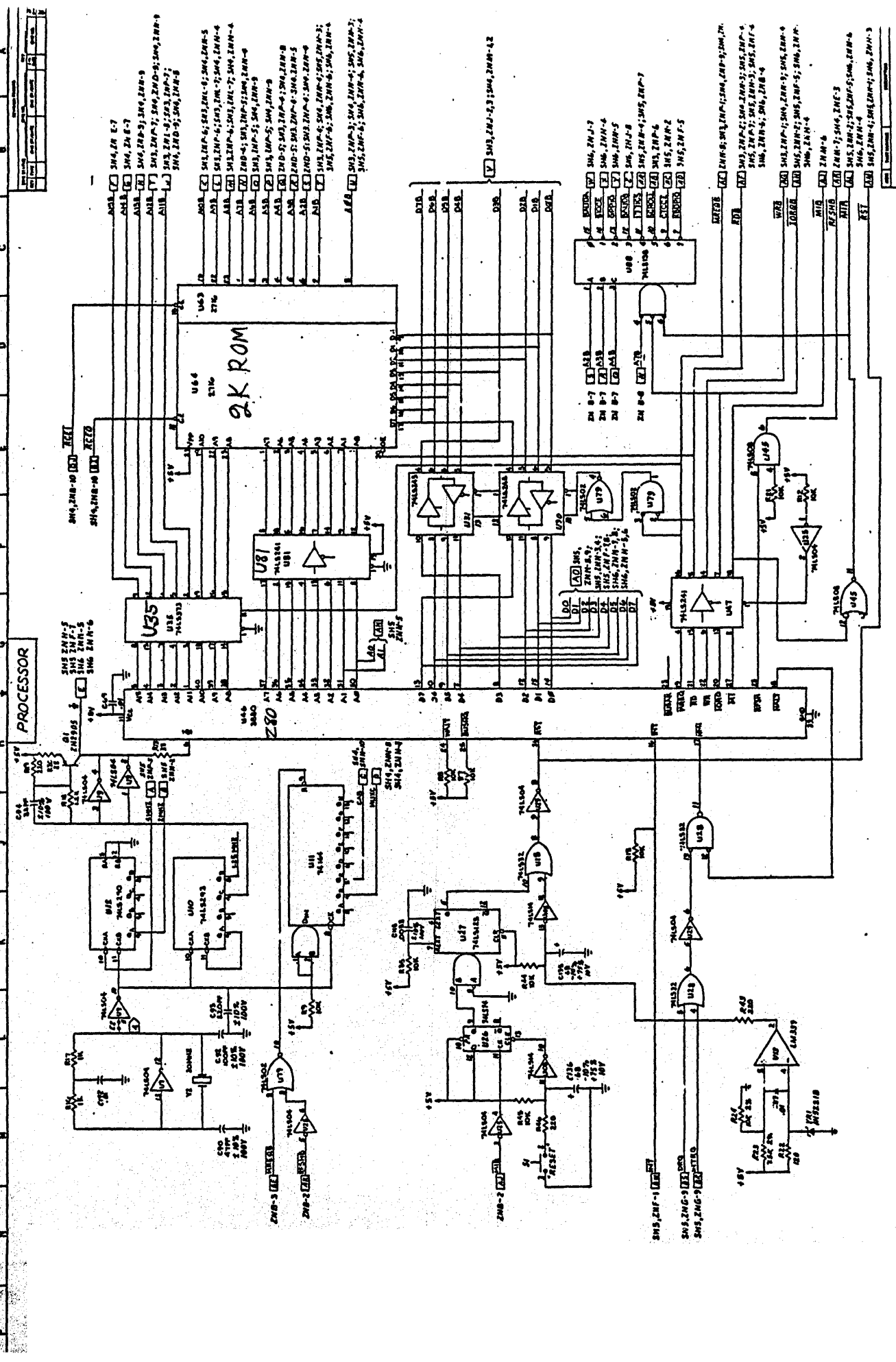

FIG. 8-1

XEROX 820



NO.	DESCRIPTION	QTY.	REV.
1
2
3
4
5
6
7
8
9
10
11
12

XEROX
SCHEMATIC 2-7-78 .179
REV. 1
DATE: 2-7-78
BY: [Signature]

RAM

XEROX

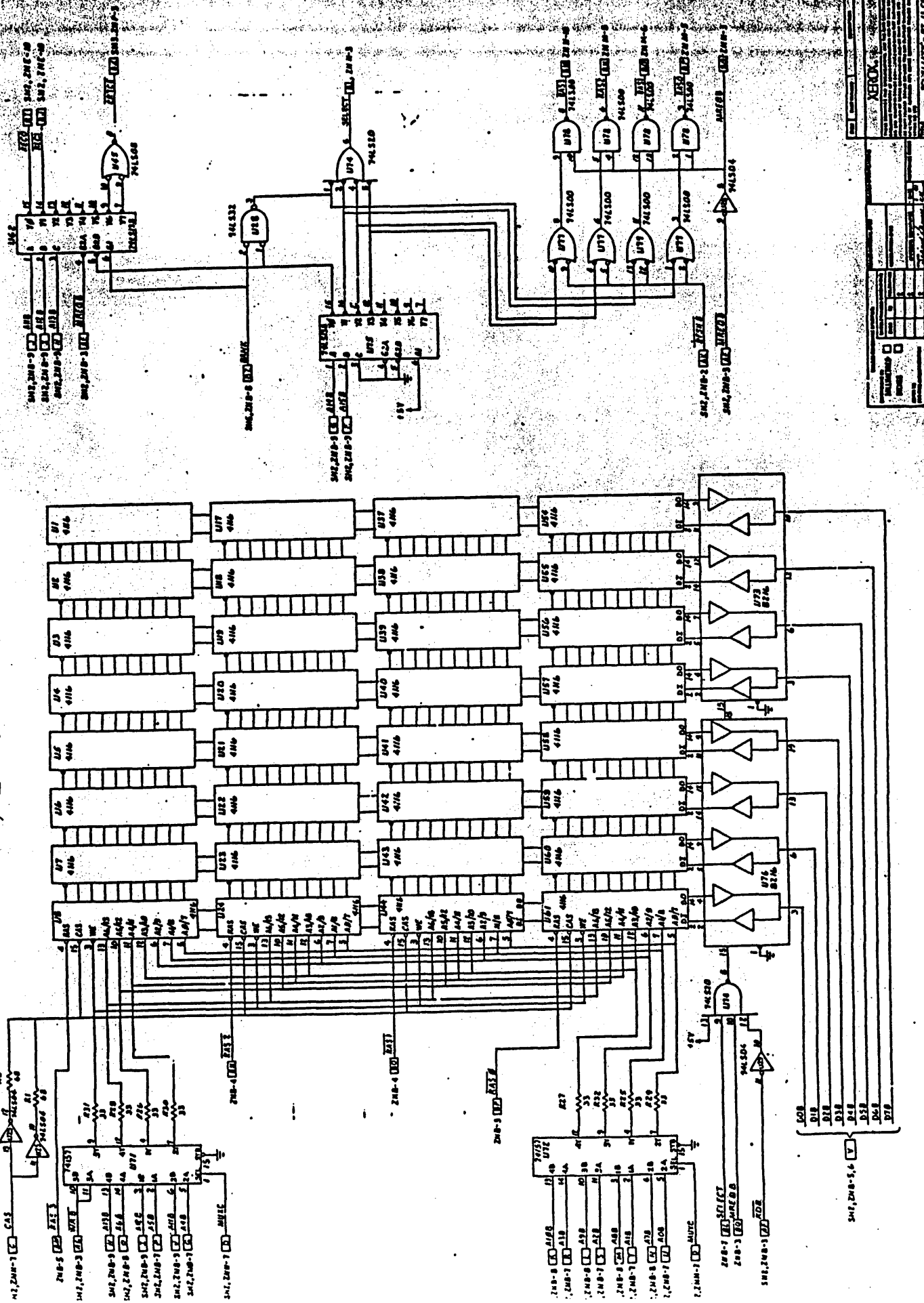

XEROX

74LS05

74LS10

74LS11

74LS12

74LS13

74LS14

74LS15

74LS16

74LS17

74LS18

74LS19

74LS20

74LS21

74LS22

74LS23

74LS24

74LS25

74LS26

74LS27

74LS28

74LS29

74LS30

74LS31

74LS32

74LS33

74LS34

74LS35

74LS36

74LS37

74LS38

74LS39

74LS40

74LS41

74LS42

74LS43

74LS44

74LS45

74LS46

74LS47

74LS48

74LS49

74LS50

74LS51

74LS52

74LS53

74LS54

74LS55

74LS56

74LS57

74LS58

74LS59

74LS60

74LS61

74LS62

74LS63

74LS64

74LS65

74LS66

74LS67

74LS68

74LS69

74LS70

74LS71

74LS72

74LS73

74LS74

74LS75

74LS76

74LS77

74LS78

74LS79

74LS80

74LS81

74LS82

74LS83

74LS84

74LS85

74LS86

74LS87

74LS88

74LS89

74LS90

74LS91

74LS92

74LS93

74LS94

74LS95

74LS96

74LS97

74LS98

74LS99

74LS100

A
 B
 C
 D
 E
 F
 G
 H
 I
 J
 K
 L
 M
 N
 P

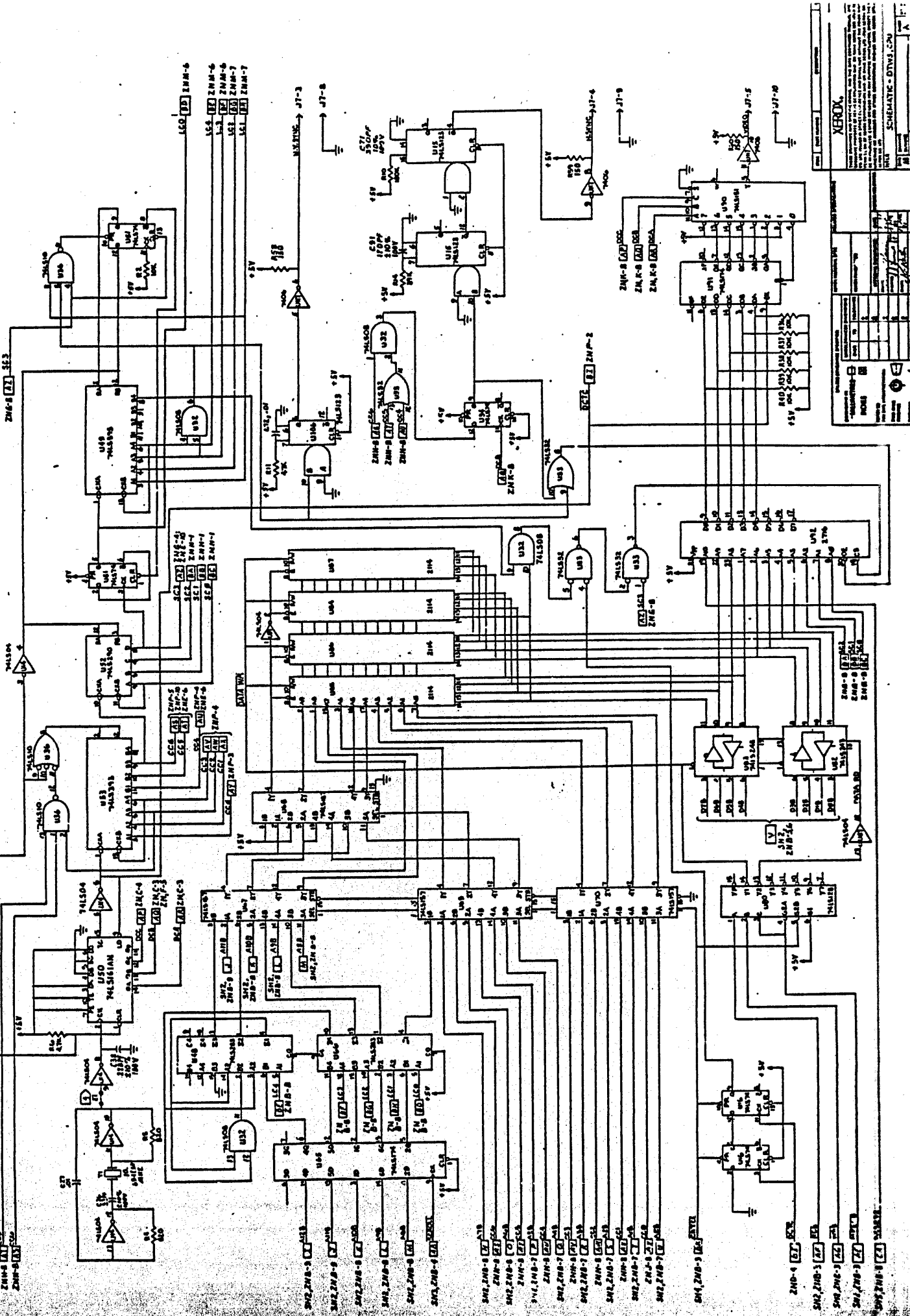

XEROX
 SCHEMATIC - DTWS-C-20

REV	DATE	DESCRIPTION
1		
2		
3		
4		
5		
6		
7		
8		
9		
10		
11		
12		
13		
14		
15		
16		

2N4001
 2N4002
 2N4003
 2N4004
 2N4005
 2N4006
 2N4007
 2N4008
 2N4009
 2N4010
 2N4011
 2N4012
 2N4013
 2N4014
 2N4015
 2N4016
 2N4017
 2N4018
 2N4019
 2N4020
 2N4021
 2N4022
 2N4023
 2N4024
 2N4025
 2N4026
 2N4027
 2N4028
 2N4029
 2N4030
 2N4031
 2N4032
 2N4033
 2N4034
 2N4035
 2N4036
 2N4037
 2N4038
 2N4039
 2N4040
 2N4041
 2N4042
 2N4043
 2N4044
 2N4045
 2N4046
 2N4047
 2N4048
 2N4049
 2N4050
 2N4051
 2N4052
 2N4053
 2N4054
 2N4055
 2N4056
 2N4057
 2N4058
 2N4059
 2N4060
 2N4061
 2N4062
 2N4063
 2N4064
 2N4065
 2N4066
 2N4067
 2N4068
 2N4069
 2N4070
 2N4071
 2N4072
 2N4073
 2N4074
 2N4075
 2N4076
 2N4077
 2N4078
 2N4079
 2N4080
 2N4081
 2N4082
 2N4083
 2N4084
 2N4085
 2N4086
 2N4087
 2N4088
 2N4089
 2N4090
 2N4091
 2N4092
 2N4093
 2N4094
 2N4095
 2N4096
 2N4097
 2N4098
 2N4099
 2N4100

FLOPPY CON'LP
KBD INPUT
CTC

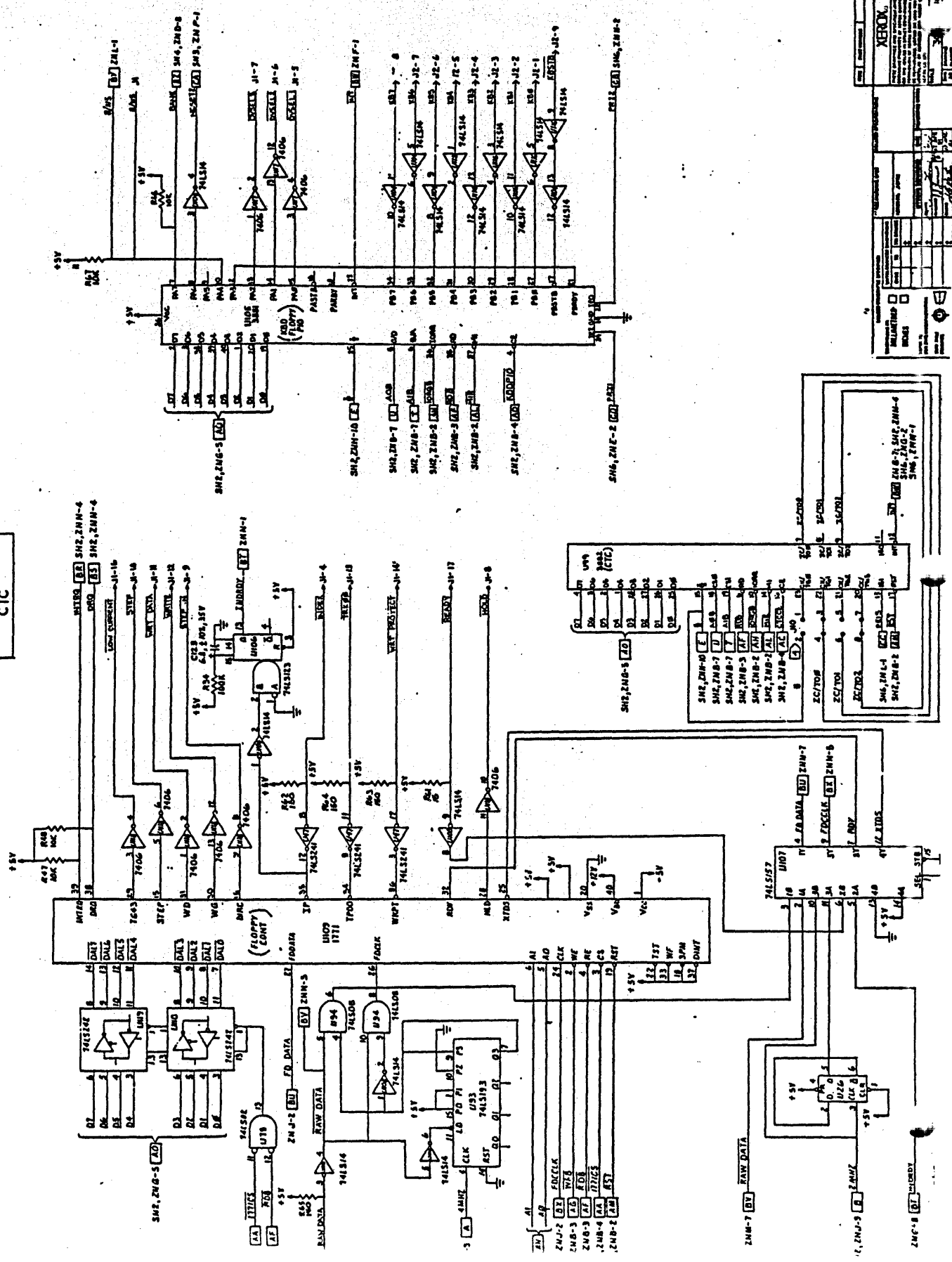

XEROX

15-0798-22A

REV	1
DATE	10/80
DESIGNED BY	
CHECKED BY	
APPROVED BY	

15-0798-22A

1	74LS14	1	74LS14
2	74LS14	2	74LS14
3	74LS14	3	74LS14
4	74LS14	4	74LS14
5	74LS14	5	74LS14
6	74LS14	6	74LS14
7	74LS14	7	74LS14
8	74LS14	8	74LS14
9	74LS14	9	74LS14
10	74LS14	10	74LS14

1	74LS14	1	74LS14
2	74LS14	2	74LS14
3	74LS14	3	74LS14
4	74LS14	4	74LS14
5	74LS14	5	74LS14
6	74LS14	6	74LS14
7	74LS14	7	74LS14
8	74LS14	8	74LS14
9	74LS14	9	74LS14
10	74LS14	10	74LS14

820-II CPU

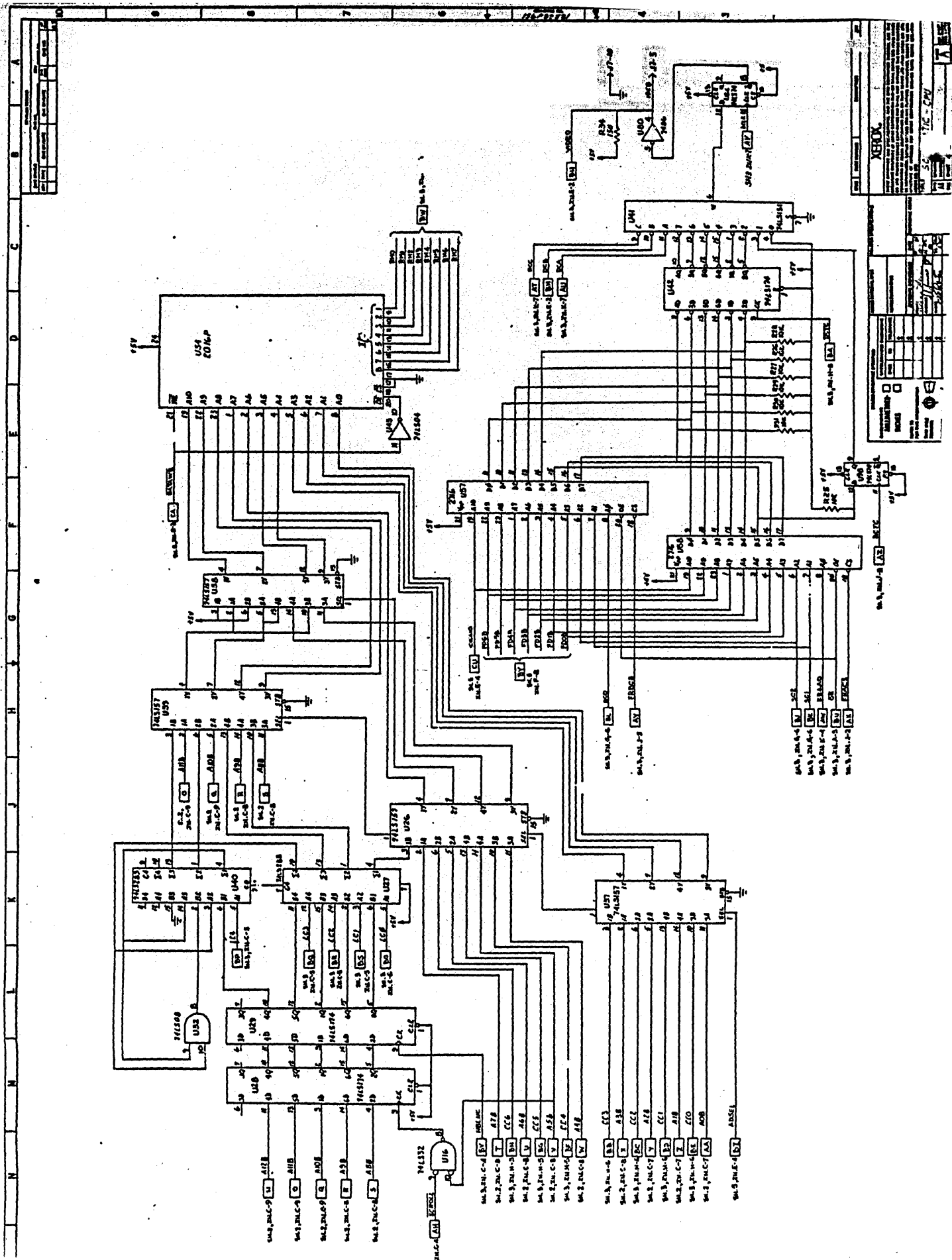

USA ROM P

74150

74151

74152

74153

74154

74155

74156

74157

74158

74159

74160

74161

74162

74163

74164

74165

74166

74167

74168

74169

74170

74171

74172

74173

74174

74175

74176

74177

74178

74179

74180

74181

74182

74183

74184

74185

74186

74187

74188

74189

74190

74191

74192

74193

74194

74195

74196

74197

74198

74199

74200

74201

74202

74203

74204

74205

74206

74207

74208

74209

74210

74211

74212

74213

74214

74215

74216

74217

74218

74219

74220

74221

74222

74223

74224

74225

74226

74227

74228

74229

74230

74231

74232

74233

74234

74235

74236

74237

74238

74239

74240

74241

74242

74243

74244

74245

74246

74247

74248

74249

74250

74251

74252

74253

74254

74255

74256

74257

74258

74259

74260

74261

74262

74263

74264

74265

74266

74267

74268

74269

74270

74271

74272

74273

74274

74275

74276

74277

74278

74279

74280

74281

74282

74283

74284

74285

74286

74287

74288

74289

74290

74291

74292

74293

74294

74295

74296

74297

74298

74299

74300

74301

74302

74303

74304

74305

74306

74307

74308

74309

74310

74311

74312

74313

74314

74315

74316

74317

74318

74319

74320

74321

74322

74323

74324

74325

74326

74327

74328

74329

74330

74331

74332

74333

74334

74335

74336

74337

74338

74339

74340

74341

74342

74343

74344

74345

74346

74347

74348

74349

74350

74351

74352

74353

74354

74355

74356

74357

74358

74359

74360

74361

74362

74363

74364

74365

74366

74367

74368

74369

74370

74371

74372

74373

74374

74375

74376

74377

74378

74379

74380

74381

74382

74383

74384

74385

74386

74387

74388

74389

74390

74391

74392

74393

74394

74395

74396

74397

74398

74399

74400

74401

74402

74403

74404

74405

74406

74407

74408

74409

74410

74411

74412

74413

74414

74415

74416

74417

74418

74419

74420

74421

74422

74423

74424

74425

74426

74427

74428

74429

74430

74431

74432

74433

74434

74435

74436

74437

74438

74439

74440

74441

74442

74443

74444

74445

74446

74447

74448

74449

74450

74451

74452

74453

74454

74455

74456

74457

74458

74459

74460

74461

74462

74463

74464

74465

74466

74467

74468

74469

74470

74471

74472

74473

74474

74475

74476

74477

74478

74479

74480

74481

74482

74483

74484

74485

74486

74487

74488

74489

74490

74491

74492

74493

74494

74495

74496

74497

74498

74499

74500

74501

74502

74503

74504

74505

74506

74507

74508

74509

74510

74511

74512

74513

74514

74515

74516

74517

74518

74519

74520

74521

74522

74523

74524

74525

74526

74527

74528

74529

74530

74531

74532

74533

74534

74535

74536

74537

74538

74539

74540

74541

74542

74543

74544

74545

74546

74547

74548

74549

74550

74551

74552

74553

74554

74555

74556

74557

74558

74559

74560

74561

74562

74563

74564

74565

74566

74567

74568

74569

74570

74571

74572

74573

74574

74575

74576

74577

74578

74579

74580

74581

74582

74583

74584

74585

74586

74587

74588

74589

74590

74591

74592

74593

74594

74595

74596

74597

74598

74599

74600

74601

74602

74603

74604

74605

74606

74607

74608

74609

74610

74611

74612

74613

74614

74615

74616

74617

74618

74619

74620

74621

74622

74623

74624

74625

74626

74627

74628

74629

74630

74631

74632

74633

74634

74635

74636

74637

74638

74639

74640

74641

74642

74643

74644

74645

74646

74647

74648

74649

74650

74651

74652

74653

74654

74655

74656

74657

74658

74659

74660

74661

74662

74663

74664

74665

74666

74667

74668

74669

74670

74671

74672

74673

74674

74675

74676

74677

74678

74679

74680

74681

74682

74683

74684

74685

74686

74687

74688

74689

74690

74691

74692

74693

74694

74695

74696

74697

74698

74699

74700

74701

74702

74703

74704

74705

74706

74707

74708

74709

74710

74711

P H N L K J I H G F E D C B A

REV	DATE	BY	CHKD
1			

XEROX	
MODEL	VTIC - CPB
DATE	
BY	
CHKD	
APPV	
REVISION	

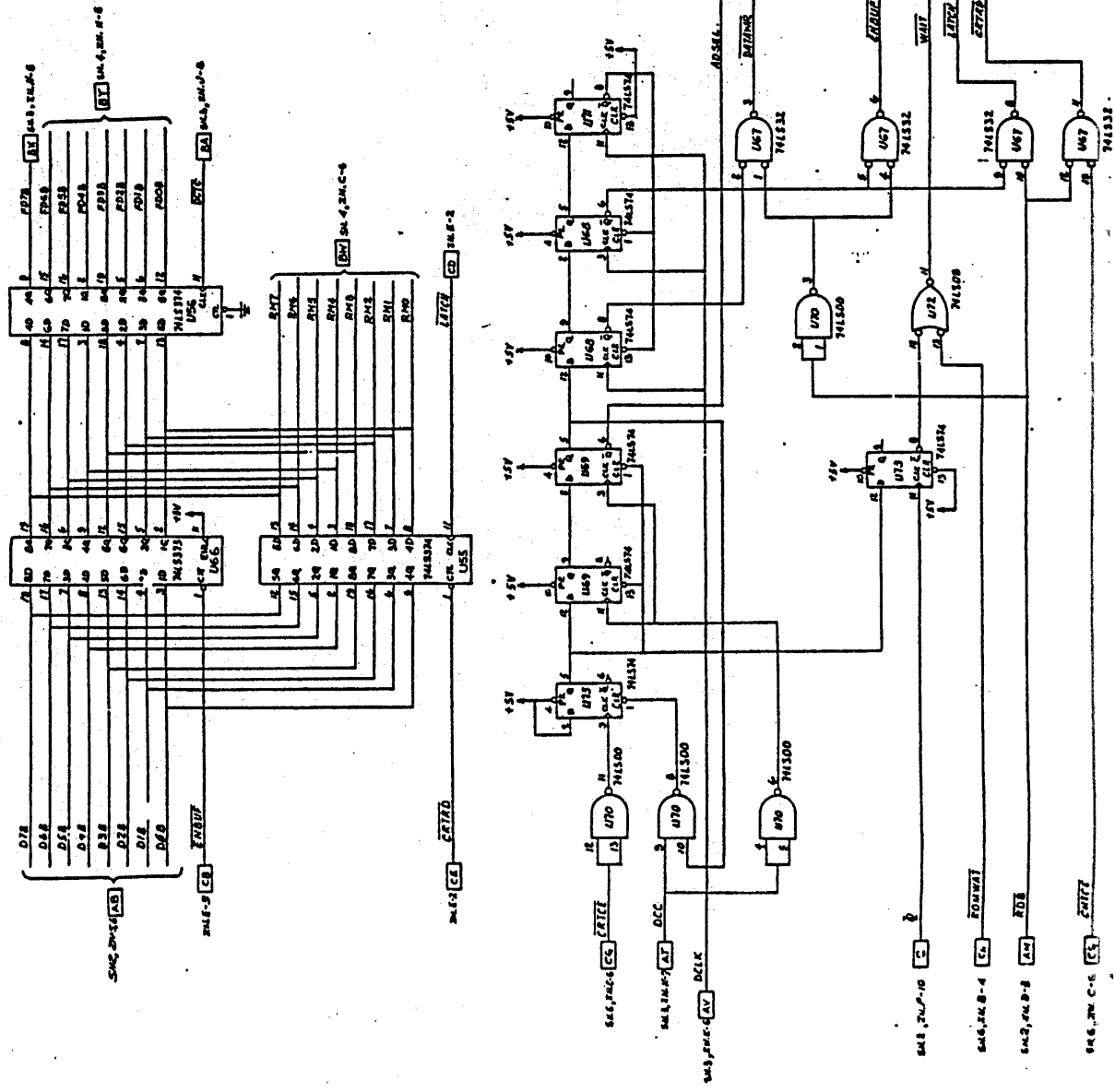

A
 B
 C
 D
 E
 F
 G
 H
 I
 J
 K
 L
 M
 N
 O
 P
 Q
 R
 S
 T
 U
 V
 W
 X
 Y
 Z
 AA
 AB
 AC
 AD
 AE
 AF
 AG
 AH
 AI
 AJ
 AK
 AL
 AM
 AN
 AO
 AP
 AQ
 AR
 AS
 AT
 AU
 AV
 AW
 AX
 AY
 AZ
 BA
 BB
 BC
 BD
 BE
 BF
 BG
 BH
 BI
 BJ
 BK
 BL
 BM
 BN
 BO
 BP
 BQ
 BR
 BS
 BT
 BU
 BV
 BW
 BX
 BY
 BZ
 CA
 CB
 CC
 CD
 CE
 CF
 CG
 CH
 CI
 CJ
 CK
 CL
 CM
 CN
 CO
 CP
 CQ
 CR
 CS
 CT
 CU
 CV
 CW
 CX
 CY
 CZ
 DA
 DB
 DC
 DD
 DE
 DF
 DG
 DH
 DI
 DJ
 DK
 DL
 DM
 DN
 DO
 DP
 DQ
 DR
 DS
 DT
 DU
 DV
 DW
 DX
 DY
 DZ
 EA
 EB
 EC
 ED
 EE
 EF
 EG
 EH
 EI
 EJ
 EK
 EL
 EM
 EN
 EO
 EP
 EQ
 ER
 ES
 ET
 EU
 EV
 EW
 EX
 EY
 EZ
 FA
 FB
 FC
 FD
 FE
 FF
 FG
 FH
 FI
 FJ
 FK
 FL
 FM
 FN
 FO
 FP
 FQ
 FR
 FS
 FT
 FU
 FV
 FW
 FX
 FY
 FZ
 GA
 GB
 GC
 GD
 GE
 GF
 GG
 GH
 GI
 GJ
 GK
 GL
 GM
 GN
 GO
 GP
 GQ
 GR
 GS
 GT
 GU
 GV
 GW
 GX
 GY
 GZ
 HA
 HB
 HC
 HD
 HE
 HF
 HG
 HH
 HI
 HJ
 HK
 HL
 HM
 HN
 HO
 HP
 HQ
 HR
 HS
 HT
 HU
 HV
 HW
 HX
 HY
 HZ
 IA
 IB
 IC
 ID
 IE
 IF
 IG
 IH
 II
 IJ
 IK
 IL
 IM
 IN
 IO
 IP
 IQ
 IR
 IS
 IT
 IU
 IV
 IW
 IX
 IY
 IZ
 JA
 JB
 JC
 JD
 JE
 JF
 JG
 JH
 JI
 JJ
 JK
 JL
 JM
 JN
 JO
 JP
 JQ
 JR
 JS
 JT
 JU
 JV
 JW
 JX
 JY
 JZ
 KA
 KB
 KC
 KD
 KE
 KF
 KG
 KH
 KI
 KJ
 KK
 KL
 KM
 KN
 KO
 KP
 KQ
 KR
 KS
 KT
 KU
 KV
 KW
 KX
 KY
 KZ
 LA
 LB
 LC
 LD
 LE
 LF
 LG
 LH
 LI
 LJ
 LK
 LL
 LM
 LN
 LO
 LP
 LQ
 LR
 LS
 LT
 LU
 LV
 LW
 LX
 LY
 LZ
 MA
 MB
 MC
 MD
 ME
 MF
 MG
 MH
 MI
 MJ
 MK
 ML
 MM
 MN
 MO
 MP
 MQ
 MR
 MS
 MT
 MU
 MV
 MW
 MX
 MY
 MZ
 NA
 NB
 NC
 ND
 NE
 NF
 NG
 NH
 NI
 NJ
 NK
 NL
 NM
 NN
 NO
 NP
 NQ
 NR
 NS
 NT
 NU
 NV
 NW
 NX
 NY
 NZ
 OA
 OB
 OC
 OD
 OE
 OF
 OG
 OH
 OI
 OJ
 OK
 OL
 OM
 ON
 OO
 OP
 OQ
 OR
 OS
 OT
 OU
 OV
 OW
 OX
 OY
 OZ
 PA
 PB
 PC
 PD
 PE
 PF
 PG
 PH
 PI
 PJ
 PK
 PL
 PM
 PN
 PO
 PP
 PQ
 PR
 PS
 PT
 PU
 PV
 PW
 PX
 PY
 PZ
 QA
 QB
 QC
 QD
 QE
 QF
 QG
 QH
 QI
 QJ
 QK
 QL
 QM
 QN
 QO
 QP
 QQ
 QR
 QS
 QT
 QU
 QV
 QW
 QX
 QY
 QZ
 RA
 RB
 RC
 RD
 RE
 RF
 RG
 RH
 RI
 RJ
 RK
 RL
 RM
 RN
 RO
 RP
 RQ
 RR
 RS
 RT
 RU
 RV
 RW
 RX
 RY
 RZ
 SA
 SB
 SC
 SD
 SE
 SF
 SG
 SH
 SI
 SJ
 SK
 SL
 SM
 SN
 SO
 SP
 SQ
 SR
 SS
 ST
 SU
 SV
 SW
 SX
 SY
 SZ
 TA
 TB
 TC
 TD
 TE
 TF
 TG
 TH
 TI
 TJ
 TK
 TL
 TM
 TN
 TO
 TP
 TQ
 TR
 TS
 TT
 TU
 TV
 TW
 TX
 TY
 TZ
 UA
 UB
 UC
 UD
 UE
 UF
 UG
 UH
 UI
 UJ
 UK
 UL
 UM
 UN
 UO
 UP
 UQ
 UR
 US
 UT
 UY
 UZ
 VA
 VB
 VC
 VD
 VE
 VF
 VG
 VH
 VI
 VJ
 VK
 VL
 VM
 VN
 VO
 VP
 VQ
 VR
 VS
 VT
 VU
 VV
 VW
 VX
 VY
 VZ
 WA
 WB
 WC
 WD
 WE
 WF
 WG
 WH
 WI
 WJ
 WK
 WL
 WM
 WN
 WO
 WP
 WQ
 WR
 WS
 WT
 WU
 WV
 WW
 WX
 WY
 WZ
 XA
 XB
 XC
 XD
 XE
 XF
 XG
 XH
 XI
 XJ
 XK
 XL
 XM
 XN
 XO
 XP
 XQ
 XR
 XS
 XT
 XU
 XV
 XW
 XX
 XY
 XZ
 YA
 YB
 YC
 YD
 YE
 YF
 YG
 YH
 YI
 YJ
 YK
 YL
 YM
 YN
 YO
 YP
 YQ
 YR
 YS
 YT
 YU
 YV
 YW
 YX
 YZ
 ZA
 ZB
 ZC
 ZD
 ZE
 ZF
 ZG
 ZH
 ZI
 ZJ
 ZK
 ZL
 ZM
 ZN
 ZO
 ZP
 ZQ
 ZR
 ZS
 ZT
 ZU
 ZV
 ZW
 ZX
 ZY
 ZZ

RAM

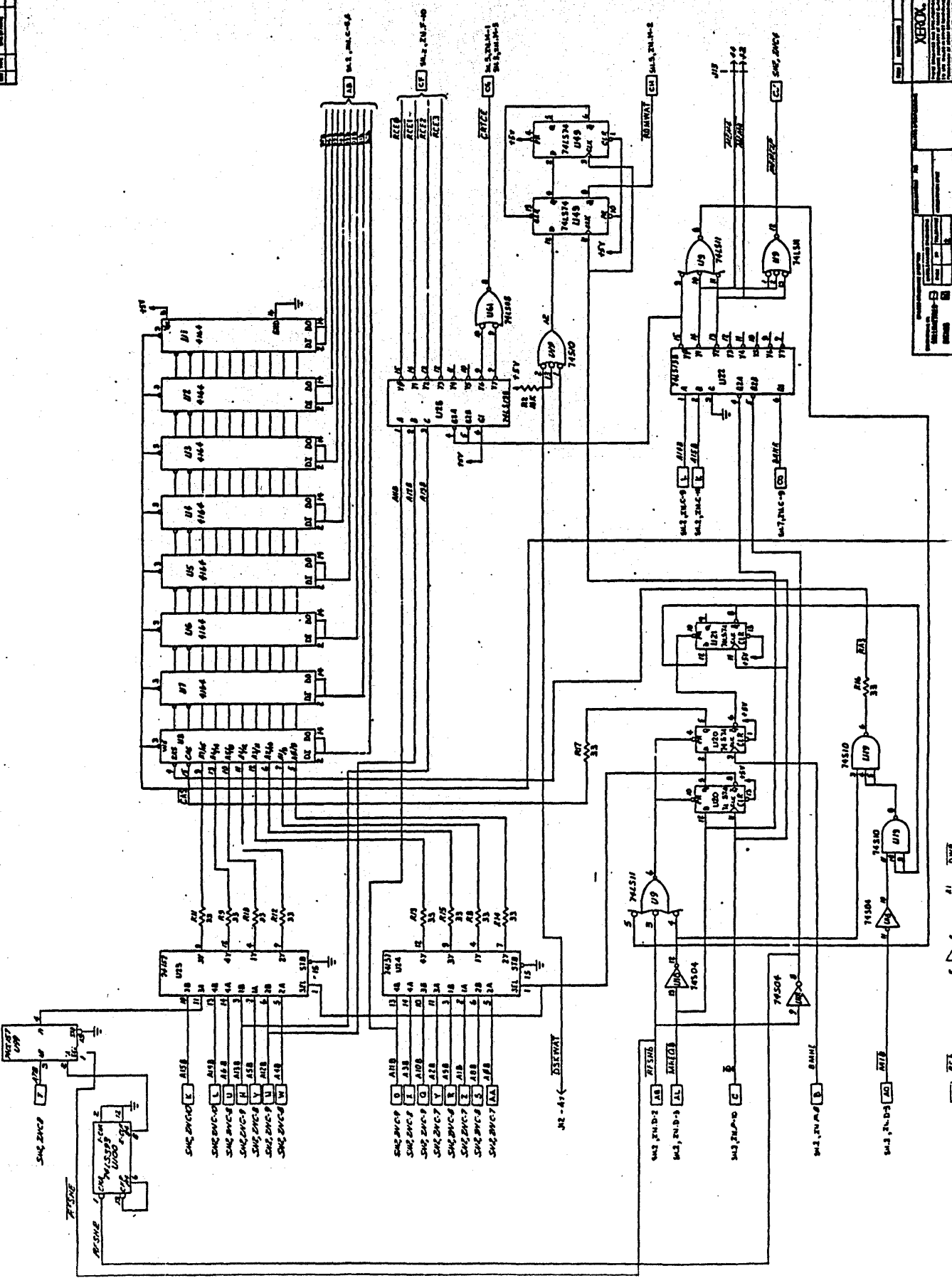

XEROX
 116-C-07
 17

A
 B
 C
 D
 E
 F
 G
 H
 I
 J
 K
 L
 M
 N
 O
 P
 Q
 R
 S
 T
 U
 V
 W
 X
 Y
 Z
 AA
 AB
 AC
 AD
 AE
 AF
 AG
 AH
 AI
 AJ
 AK
 AL
 AM
 AN
 AO
 AP
 AQ
 AR
 AS
 AT
 AU
 AV
 AW
 AX
 AY
 AZ
 BA
 BB
 BC
 BD
 BE
 BF
 BG
 BH
 BI
 BJ
 BK
 BL
 BM
 BN
 BO
 BP
 BQ
 BR
 BS
 BT
 BU
 BV
 BW
 BX
 BY
 BZ
 CA
 CB
 CC
 CD
 CE
 CF
 CG
 CH
 CI
 CJ
 CK
 CL
 CM
 CN
 CO
 CP
 CQ
 CR
 CS
 CT
 CU
 CV
 CW
 CX
 CY
 CZ
 DA
 DB
 DC
 DD
 DE
 DF
 DG
 DH
 DI
 DJ
 DK
 DL
 DM
 DN
 DO
 DP
 DQ
 DR
 DS
 DT
 DU
 DV
 DW
 DX
 DY
 DZ
 EA
 EB
 EC
 ED
 EE
 EF
 EG
 EH
 EI
 EJ
 EK
 EL
 EM
 EN
 EO
 EP
 EQ
 ER
 ES
 ET
 EU
 EV
 EW
 EX
 EY
 EZ
 FA
 FB
 FC
 FD
 FE
 FF
 FG
 FH
 FI
 FJ
 FK
 FL
 FM
 FN
 FO
 FP
 FQ
 FR
 FS
 FT
 FU
 FV
 FW
 FX
 FY
 FZ
 GA
 GB
 GC
 GD
 GE
 GF
 GG
 GH
 GI
 GJ
 GK
 GL
 GM
 GN
 GO
 GP
 GQ
 GR
 GS
 GT
 GU
 GV
 GW
 GX
 GY
 GZ
 HA
 HB
 HC
 HD
 HE
 HF
 HG
 HH
 HI
 HJ
 HK
 HL
 HM
 HN
 HO
 HP
 HQ
 HR
 HS
 HT
 HU
 HV
 HW
 HX
 HY
 HZ
 IA
 IB
 IC
 ID
 IE
 IF
 IG
 IH
 II
 IJ
 IK
 IL
 IM
 IN
 IO
 IP
 IQ
 IR
 IS
 IT
 IU
 IV
 IW
 IX
 IY
 IZ
 JA
 JB
 JC
 JD
 JE
 JF
 JG
 JH
 JI
 JJ
 JK
 JL
 JM
 JN
 JO
 JP
 JQ
 JR
 JS
 JT
 JU
 JV
 JW
 JX
 JY
 JZ
 KA
 KB
 KC
 KD
 KE
 KF
 KG
 KH
 KI
 KJ
 KK
 KL
 KM
 KN
 KO
 KP
 KQ
 KR
 KS
 KT
 KU
 KV
 KW
 KX
 KY
 KZ
 LA
 LB
 LC
 LD
 LE
 LF
 LG
 LH
 LI
 LJ
 LK
 LL
 LM
 LN
 LO
 LP
 LQ
 LR
 LS
 LT
 LU
 LV
 LW
 LX
 LY
 LZ
 MA
 MB
 MC
 MD
 ME
 MF
 MG
 MH
 MI
 MJ
 MK
 ML
 MN
 MO
 MP
 MQ
 MR
 MS
 MT
 MU
 MV
 MW
 MX
 MY
 MZ
 NA
 NB
 NC
 ND
 NE
 NF
 NG
 NH
 NI
 NJ
 NK
 NL
 NM
 NO
 NP
 NQ
 NR
 NS
 NT
 NU
 NV
 NW
 NX
 NY
 NZ
 OA
 OB
 OC
 OD
 OE
 OF
 OG
 OH
 OI
 OJ
 OK
 OL
 OM
 ON
 OO
 OP
 OQ
 OR
 OS
 OT
 OU
 OV
 OW
 OX
 OY
 OZ
 PA
 PB
 PC
 PD
 PE
 PF
 PG
 PH
 PI
 PJ
 PK
 PL
 PM
 PN
 PO
 PP
 PQ
 PR
 PS
 PT
 PU
 PV
 PW
 PX
 PY
 PZ
 QA
 QB
 QC
 QD
 QE
 QF
 QG
 QH
 QI
 QJ
 QK
 QL
 QM
 QN
 QO
 QP
 QQ
 QR
 QS
 QT
 QU
 QV
 QW
 QX
 QY
 QZ
 RA
 RB
 RC
 RD
 RE
 RF
 RG
 RH
 RI
 RJ
 RK
 RL
 RM
 RN
 RO
 RP
 RQ
 RR
 RS
 RT
 RU
 RV
 RW
 RX
 RY
 RZ
 SA
 SB
 SC
 SD
 SE
 SF
 SG
 SH
 SI
 SJ
 SK
 SL
 SM
 SN
 SO
 SP
 SQ
 SR
 SS
 ST
 SU
 SV
 SW
 SX
 SY
 SZ
 TA
 TB
 TC
 TD
 TE
 TF
 TG
 TH
 TI
 TJ
 TK
 TL
 TM
 TN
 TO
 TP
 TQ
 TR
 TS
 TU
 TV
 TW
 TX
 TY
 TZ
 UA
 UB
 UC
 UD
 UE
 UF
 UG
 UH
 UI
 UJ
 UK
 UL
 UM
 UN
 UO
 UP
 UQ
 UR
 US
 UT
 UY
 UZ
 VA
 VB
 VC
 VD
 VE
 VF
 VG
 VH
 VI
 VJ
 VK
 VL
 VM
 VN
 VO
 VP
 VQ
 VR
 VS
 VT
 VU
 VV
 VW
 VX
 VY
 VZ
 WA
 WB
 WC
 WD
 WE
 WF
 WG
 WH
 WI
 WJ
 WK
 WL
 WM
 WN
 WO
 WP
 WQ
 WR
 WS
 WT
 WU
 WV
 WW
 WX
 WY
 WZ
 XA
 XB
 XC
 XD
 XE
 XF
 XG
 XH
 XI
 XJ
 XK
 XL
 XM
 XN
 XO
 XP
 XQ
 XR
 XS
 XT
 XU
 XV
 XW
 XX
 XY
 XZ
 YA
 YB
 YC
 YD
 YE
 YF
 YG
 YH
 YI
 YJ
 YK
 YL
 YM
 YN
 YO
 YP
 YQ
 YR
 YS
 YT
 YU
 YV
 YW
 YX
 YZ
 ZA
 ZB
 ZC
 ZD
 ZE
 ZF
 ZG
 ZH
 ZI
 ZJ
 ZK
 ZL
 ZM
 ZN
 ZO
 ZP
 ZQ
 ZR
 ZS
 ZT
 ZU
 ZV
 ZW
 ZX
 ZY
 ZZ

GTC

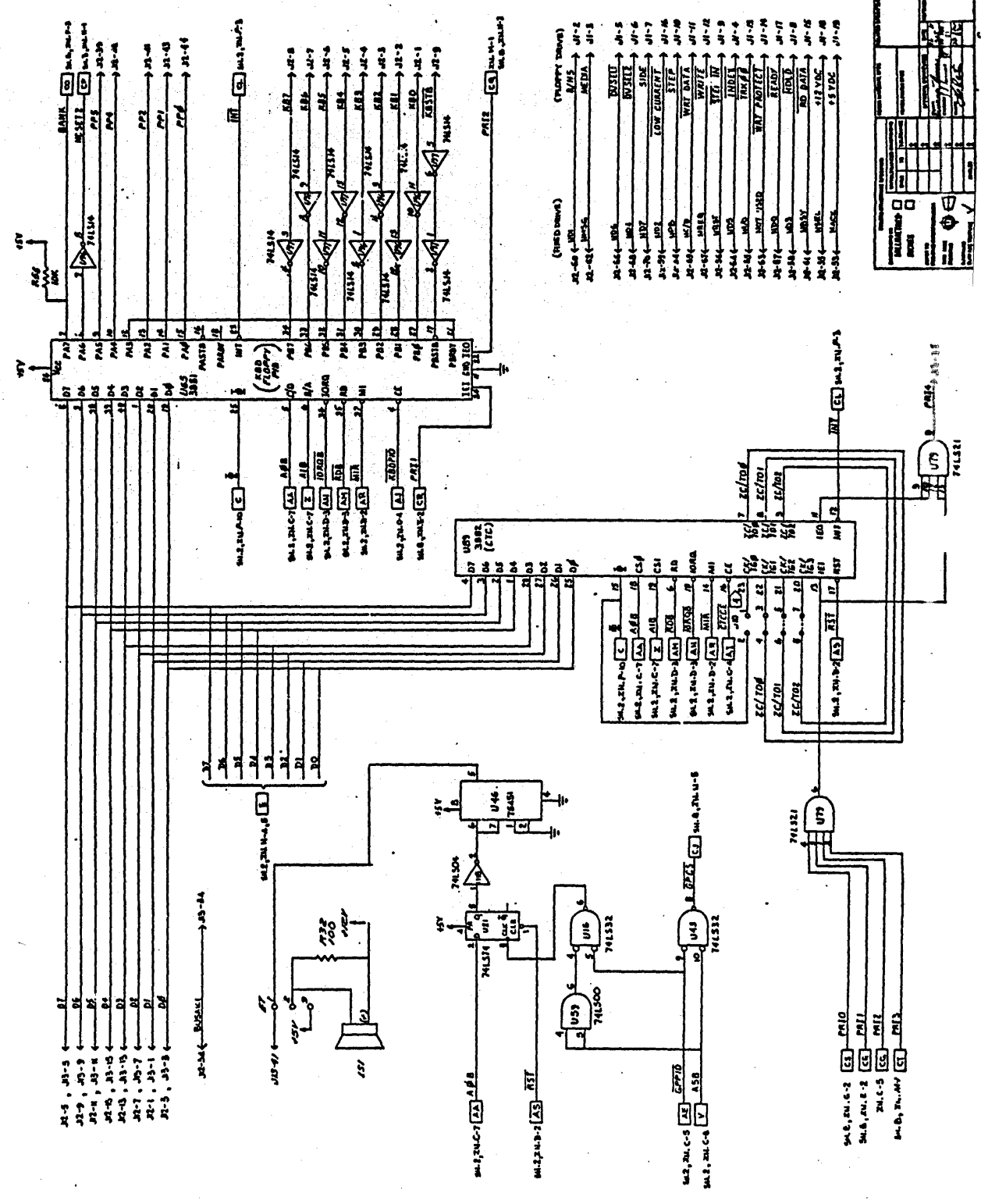

(USED VALUES)

22-44	10K	RES	RES
22-45	10K	RES	RES
22-46	10K	RES	RES
22-47	10K	RES	RES
22-48	10K	RES	RES
22-49	10K	RES	RES
22-50	10K	RES	RES
22-51	10K	RES	RES
22-52	10K	RES	RES
22-53	10K	RES	RES
22-54	10K	RES	RES
22-55	10K	RES	RES
22-56	10K	RES	RES
22-57	10K	RES	RES
22-58	10K	RES	RES
22-59	10K	RES	RES
22-60	10K	RES	RES
22-61	10K	RES	RES
22-62	10K	RES	RES
22-63	10K	RES	RES
22-64	10K	RES	RES
22-65	10K	RES	RES
22-66	10K	RES	RES
22-67	10K	RES	RES
22-68	10K	RES	RES
22-69	10K	RES	RES
22-70	10K	RES	RES
22-71	10K	RES	RES
22-72	10K	RES	RES
22-73	10K	RES	RES
22-74	10K	RES	RES
22-75	10K	RES	RES
22-76	10K	RES	RES
22-77	10K	RES	RES
22-78	10K	RES	RES
22-79	10K	RES	RES
22-80	10K	RES	RES
22-81	10K	RES	RES
22-82	10K	RES	RES
22-83	10K	RES	RES
22-84	10K	RES	RES
22-85	10K	RES	RES
22-86	10K	RES	RES
22-87	10K	RES	RES
22-88	10K	RES	RES
22-89	10K	RES	RES
22-90	10K	RES	RES
22-91	10K	RES	RES
22-92	10K	RES	RES
22-93	10K	RES	RES
22-94	10K	RES	RES
22-95	10K	RES	RES
22-96	10K	RES	RES
22-97	10K	RES	RES
22-98	10K	RES	RES
22-99	10K	RES	RES
22-100	10K	RES	RES

XEROX
 MODEL 801
 SERIAL NO. 12345678
 DATE: 10/15/78
 BY: J. SMITH
 CHECKED: M. JONES
 APPROVED: R. BROWN
 PARTS LIST: 100-100000-001
 100-100000-002
 100-100000-003
 100-100000-004
 100-100000-005
 100-100000-006
 100-100000-007
 100-100000-008
 100-100000-009
 100-100000-010
 100-100000-011
 100-100000-012
 100-100000-013
 100-100000-014
 100-100000-015
 100-100000-016
 100-100000-017
 100-100000-018
 100-100000-019
 100-100000-020

P	N	M	L	K	J	I	H	G	F	E	D	C	B	A
---	---	---	---	---	---	---	---	---	---	---	---	---	---	---

YES UNLESS OTHERWISE SPECIFIED:
 R RESISTANCE VALUES ARE IN OHMS, 1.5K, 1.5M
 C CAPACITANCE VALUES ARE IN MICROGRAMS, 100, 500, 50K

3. PUNCH ASSIGNMENT TABLE

ACT. DESIGNATION	BY	AS	AK
U1-01, U1A	7	M	
U1-02, U1B, U1C	8	TS	
U1-03	20	ET	70

4. REFERENCE DESIGNATIONS

LAST USED	NOT USED
U1A	
U1B	
U1C	

5. LAST MICROCONNECT LETTER USED "N"
 6. SPARE ENDS:

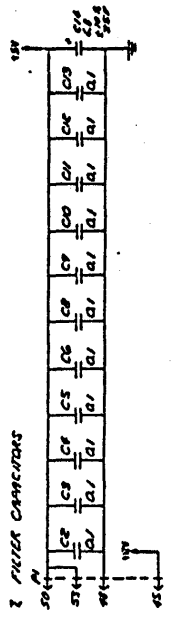
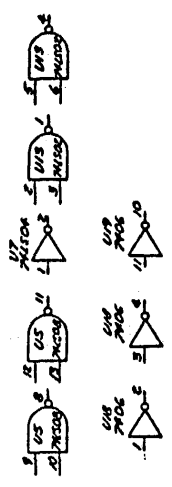

XEROX

10077 CO. 78-2187

REPRODUCTION OF THIS DOCUMENT IS PROHIBITED WITHOUT THE WRITTEN PERMISSION OF XEROX CORPORATION.

DATE: 11/15/78

BY: [Signature]

PROJECT: [Blank]

DESIGNER: [Blank]

CHECKED: [Blank]

APPROVED: [Blank]

SCALE: [Blank]

FIG. NO.: [Blank]

SHEET NO. 1 OF 1

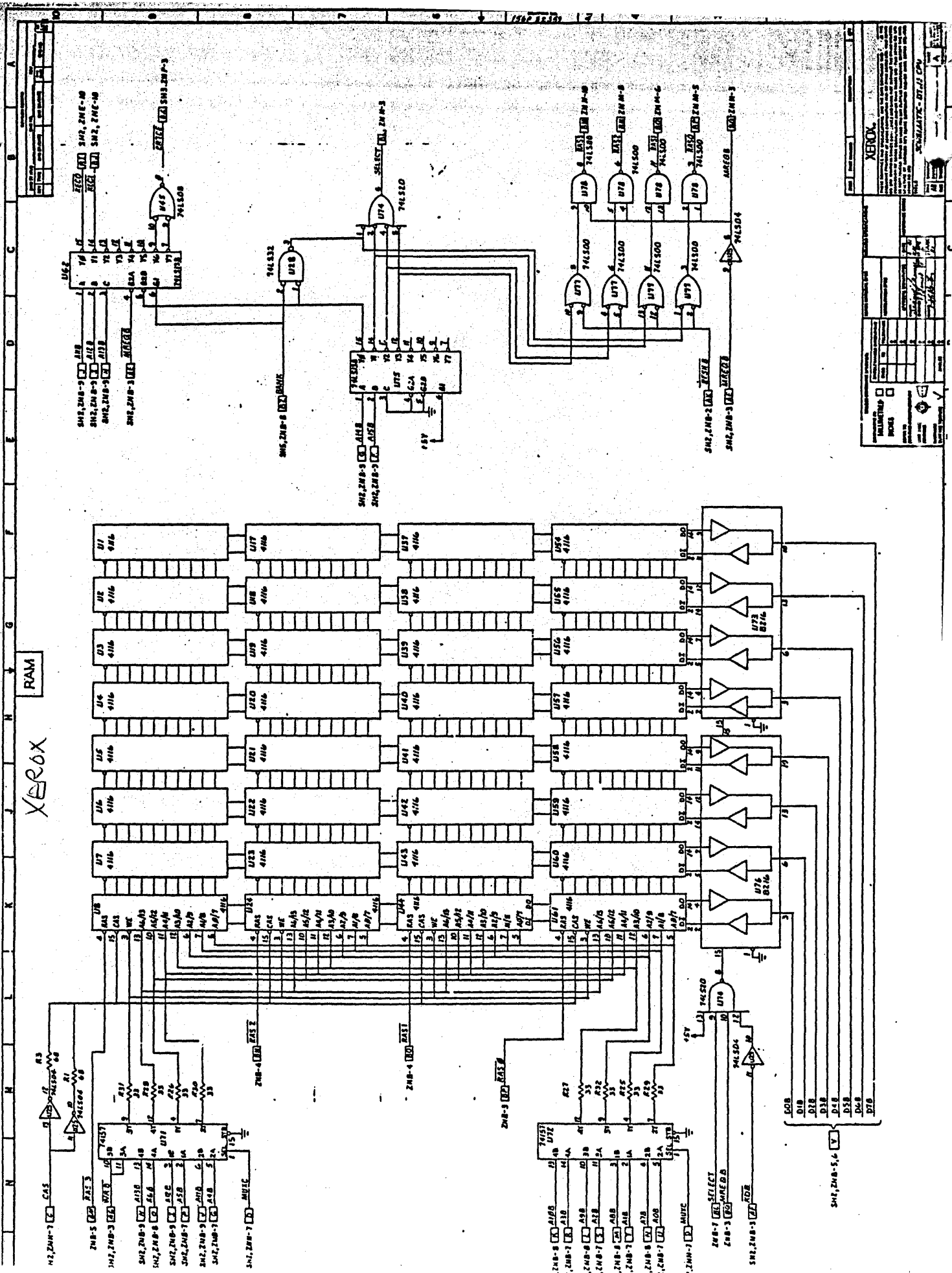

XEROX

RAM

XEROX

REVISIONS

NO.	DATE	DESCRIPTION
1		
2		
3		
4		
5		
6		
7		
8		
9		
10		

DESIGNED BY: _____

CHECKED BY: _____

DATE: _____

15V

FLOPPY DAUGHTER PWA

FIXED DAUGHTER PWA

P Q R S T U V W X Y Z AA AB AC AD AE AF AG AH AI AJ AK AL AM AN AO AP AQ AR AS AT AU AV AW AX AY AZ BA BB BC BD BE BF BG BH BI BJ BK BL BM BN BO BP BQ BR BS BT BU BV BW BX BY BZ CA CB CC CD CE CF CG CH CI CJ CK CL CM CN CO CP CQ CR CS CT CU CV CW CX CY CZ DA DB DC DD DE DF DG DH DI DJ DK DL DM DN DO DP DQ DR DS DT DU DV DW DX DY DZ EA EB EC ED EE EF EG EH EI EJ EK EL EM EN EO EP EQ ER ES ET EU EV EW EX EY EZ FA FB FC FD FE FF FG FH FI FJ FK FL FM FN FO FP FQ FR FS FT FU FV FW FX FY FZ GA GB GC GD GE GF GG GH GI GJ GK GL GM GN GO GP GQ GR GS GT GU GV GW GX GY GZ HA HB HC HD HE HF HG HH HI HJ HK HL HM HN HO HP HQ HR HS HT HU HV HW HX HY HZ IA IB IC ID IE IF IG IH II IJ IK IL IM IN IO IP IQ IR IS IT IU IV IW IX IY IZ JA JB JC JD JE JF JG JH JI JJ JK JL JM JN JO JP JQ JR JS JT JU JV JW JX JY JZ KA KB KC KD KE KF KG KH KI KJ KK KL KM KN KO KP KQ KR KS KT KU KV KW KX KY KZ LA LB LC LD LE LF LG LH LI LJ LK LL LM LN LO LP LQ LR LS LT LU LV LW LX LY LZ MA MB MC MD ME MF MG MH MI MJ MK ML MN MO MP MQ MR MS MT MU MV MW MX MY MZ NA NB NC ND NE NF NG NH NI NJ NK NL NO NP NQ NR NS NT NU NV NW NX NY NZ OA OB OC OD OE OF OG OH OI OJ OK OL OM ON OO OP OQ OR OS OT OU OV OW OX OY OZ PA PB PC PD PE PF PG PH PI PJ PK PL PM PN PO PP PQ PR PS PT PU PV PW PX PY PZ QA QB QC QD QE QF QG QH QI QJ QK QL QM QN QO QP QQ QR QS QT QU QV QW QX QY QZ RA RB RC RD RE RF RG RH RI RJ RK RL RM RN RO RP RQ RR RS RT RU RV RW RX RY RZ SA SB SC SD SE SF SG SH SI SJ SK SL SM SN SO SP SQ SR SS ST SU SV SW SX SY SZ TA TB TC TD TE TF TG TH TI TJ TK TL TM TN TO TP TQ TR TS TT TU TV TW TX TY TZ UA UB UC UD UE UF UG UH UI UJ UK UL UM UN UO UP UQ UR US UT UV UW UX UY UZ VA VB VC VD VE VF VG VH VI VJ VK VL VM VN VO VP VQ VR VS VT VU VV VW VX VY VZ WA WB WC WD WE WF WG WH WI WJ WK WL WM WN WO WP WQ WR WS WT WU WV WW WX WY WZ XA XB XC XD XE XF XG XH XI XJ XK XL XM XN XO XP XQ XR XS XT XU XV XW XX XY XZ YA YB YC YD YE YF YG YH YI YJ YK YL YM YN YO YP YQ YR YS YT YU YV YW YX YY YZ ZA ZB ZC ZD ZE ZF ZG ZH ZI ZJ ZK ZL ZM ZN ZO ZP ZQ ZR ZS ZT ZU ZV ZW ZX ZY ZZ

REV	DATE	BY	CHKD
1			

POWER DISTRIBUTION SHEET
 MICROPROCESSOR - 201603, 10P

REV	DATE	BY	CHKD
1			

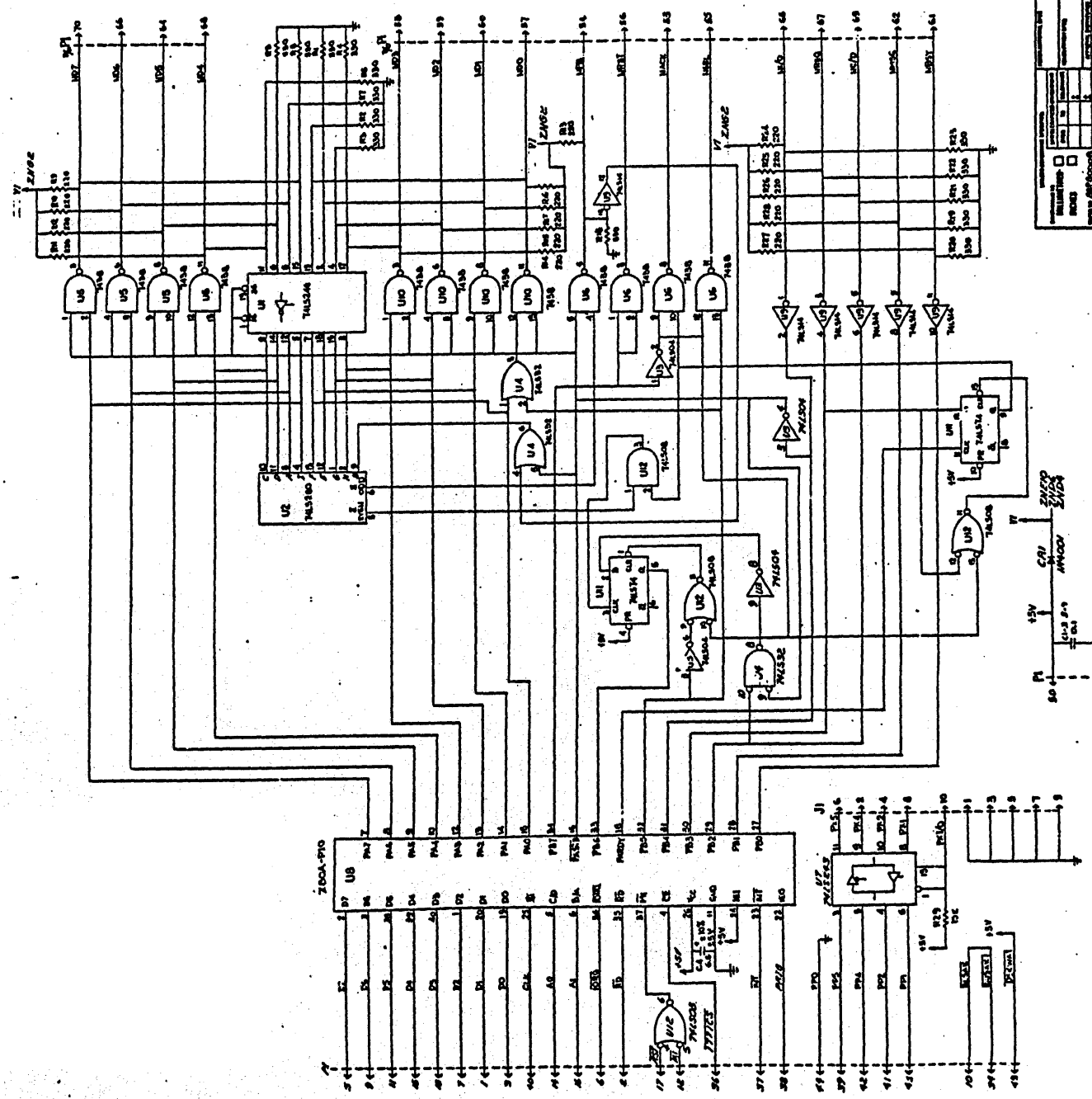

REV	DATE	BY	CHKD
1			

REV	DATE	BY	CHKD
1			

REV	DATE	BY	CHKD
1			

REV	DATE	BY	CHKD
1			

REV	DATE	BY	CHKD
1			

REV	DATE	BY	CHKD
1			

STAPLE

STAPLE

Before stapling please be sure that all information is completed on reverse side

STAPLE

STAPLE

FOLD



BUSINESS REPLY MAIL

No postage stamp necessary if mailed in the United States

First Class
Permit No. 16500
Dallas, Texas



Postage will be paid by:
Xerox Corporation

**XEROX CORPORATION
FIELD ENGINEERING
1341 W. MOCKINGBIRD LANE
DALLAS, TEXAS 75247**

**ATTN; MANAGER FIELD ENGINEERING
MS 303**

FOLD

STAPLE

STAPLE

STAPLE

STAPLE

Before stapling please be sure that all information is completed on reverse side

